

User & Operation Manual

MG-SERIES CHILLERS

Document	M-007	Version	1.5	Date	19/06/25	Author	JWB	Page	1
----------	-------	---------	-----	------	----------	--------	-----	------	---



MGT chiller pictured

User & Operation Manual

MG-SERIES CHILLERS

Document	M-007	Version	1.5	Date	19/06/25	Author	JWB	Page	2
-----------------	-------	----------------	-----	-------------	----------	---------------	-----	-------------	---

CONTENTS

1.0 INTRODUCTION	4
2.0 IMPORTANT INFORMATION	5
2.1 INTENDED USE	5
2.2 SAFETY NOTICES	6
2.3 WASTE DISPOSAL.....	9
2.4 MODEL NUMBERING	10
2.5 UNPACKING UNITS.....	11
2.6 SITE REQUIREMENTS	11
2.7 WARRANTY REGISTRATION	13
3.0 PRODUCT SPECIFICATIONS	14
3.1 MG-SERIES (ALL STANDARD VARIANTS)	14
4.0 QUICK START GUIDE	15
5.0 INSTALLATION.....	15
5.1 HOSE RECOMMENDATIONS	15
5.2 FLUID FITTINGS	16
5.3 BACKFILLING.....	16
5.4 VOLTAGE SELECTION	16
5.5 FILLING PROCEDURE	17
5.6 DRAINING A SYSTEM.....	18
6.0 CONTROLLER OPERATION	19
6.1 KR1 CONTROLLER – MGC MODELS	19
6.1.1 CHANGING SETPOINT	20
6.2 TOUCHSCREEN CONTROLLER – MGT MODELS	21
6.3 REGULATING PRESSURE/FLOW	22
7.0 BASIC TROUBLESHOOTING.....	23
8.0 END USER MAINTENANCE.....	25
9.0 DECLARATION OF CONFORMITY	26
10.0 REFRIGERANT & HEAT TRANSFER FLUID SAFETY DATA SHEETS	27
10.1 R290 SAFETY DATA SHEET.....	28

User & Operation Manual

MG-SERIES CHILLERS

Document	M-007	Version	1.5	Date	19/06/25	Author	JWB	Page	3
-----------------	-------	----------------	-----	-------------	----------	---------------	-----	-------------	---

10.2 HEXID A4 SAFETY DATA SHEET	34
10.3 HEXID A6 SAFETY DATA SHEET	40
10.4 COOLFLOW EG SAFETY DATA SHEET.....	46



User & Operation Manual

MG-SERIES CHILLERS

Document	M-007	Version	1.5	Date	19/06/25	Author	JWB	Page	4
-----------------	-------	----------------	-----	-------------	----------	---------------	-----	-------------	---

1.0 INTRODUCTION

By selecting an ATC product, you have invested in many years of experience in the design and manufacture of precision temperature control instrumentation.

ATC has built your unit without compromise to meet the objectives of performance and reliability. Please read this manual carefully to ensure you understand the operation of the machine and how to use the unit safely and efficiently.

CAUTION



Please read this User & Operation Manual in full. For maintenance tasks beyond that of routine cleaning, please consult the separate Maintenance Manual. This contains further information and schematics for the use of suitably qualified personnel.

Contact information

If you have any questions regarding installation or repair of this unit, please contact ATC direct.

Applied Thermal Control Ltd.

39 Hayhill Industrial Estate, Barrow Upon Soar

Leicestershire,

LE12 8LD

United Kingdom

Tel: +44 (0) 1530 839998

E-mail: support@app-therm.com



Document	M-007	Version	1.5	Date	19/06/25	Author	JWB	Page	5
-----------------	-------	----------------	-----	-------------	----------	---------------	-----	-------------	---

2.0 IMPORTANT INFORMATION

2.1 INTENDED USE

Applied Thermal Control products have been designed to control the temperature of specific fluids. The units feature inlet and outlet connections for the temperature control of external systems (process fluid circuit).

Applied Thermal Control products are not suitable for direct temperature control of foods, pharmaceutical or medical products. This is defined as unprotected contact of the object with the process fluid used by the chiller.

The product must be used in line with the instructions contained within this manual. A separate maintenance manual is also available. Particular attention should be given to the safety notices prior to installing and operating the machine.

This appliance is not intended for use by persons with reduced physical, sensory or mental capabilities, or lack of experience and knowledge, unless they have been given supervision or instruction concerning use of the appliance by a person responsible for their safety.

Document	M-007	Version	1.5	Date	19/06/25	Author	JWB	Page	6
----------	-------	---------	-----	------	----------	--------	-----	------	---



2.2 SAFETY NOTICES

R290 refrigerant is an environmentally friendly alternative to HFC refrigerants. However, it is classified as a highly flammable gas. At the same temperature and pressure, R290 is heavier than air and usually reaches higher concentrations near the ground. R290 is odourless, but can be easily detected with commercially available gas detectors and leak detection devices.

Additional information regarding R290 refrigerant can be found in section 10.1 R290 . The refrigerant type and charge is always labelled on the unit.

For your safety, we draw your attention to the following WARNING and CAUTION marks throughout the manual. Warning symbols can be found on the unit. Ensure you have read through all warnings before starting the unit.

The safe operation of ATC products always remains the responsibility of the operator. This equipment is intended to be used as a liquid temperature conditioning device – it requires no external pump, nor any further manipulation of temperature. If the equipment is used in a manner not specified by the manufacturer, the protection provided by the equipment may be impaired. Failure to comply with a ‘WARNING’ may result in personal injury or death. ATC does not accept any liability for injury caused through misuse of this equipment.

REFRIGERANT: R290	
For your safety, we draw your attention to the following warning and caution marks throughout the manual Identified by the following symbols. Where relevant, these are also labelled on the machine. All warnings and cautions should be read prior to starting the machine.	
⚠ WARNING	
	Warnings denote a hazard that MAY cause serious personal injury or death.
⚠ CAUTION	
	Cautions denote a hazard that MAY cause minor personal injury or damage/failure of the product or facility.
<p>The safe operation of ATC products remains the responsibility of the operator at all times. This equipment is intended to be used as a liquid temperature conditioning device – it requires no external pump, nor any further manipulation of temperature.</p> <p>If the equipment is used in a manner not specified by the manufacturer, the protection provided by the equipment may be impaired. Failure to comply with a ‘warning’ may result in personal injury or death.</p> <p style="text-align: center;">ATC does not accept any liability for injury or damage caused through misuse of this equipment.</p>	

Document	M-007	Version	1.5	Date	19/06/25	Author	JWB	Page	7
----------	-------	---------	-----	------	----------	--------	-----	------	---

WARNING



- This appliance should only be installed by persons who are appropriately trained, skilled and competent to carry out the work properly and safely. Servicing and repair is to be undertaken by qualified engineers for the handling of hydrocarbon refrigerants.
- Do not store explosive substances such as aerosol cans with a flammable propellant within or close to this appliance.
- Do not damage the refrigerating circuit
- Do not use electrical appliances inside the enclosure of this appliance unless they are of the type recommended by the manufacturer
- To be installed in accordance with the Safety Standard for Refrigeration Systems, ANSI/ASHRAE 15 or local equivalent.
- Adequate ventilation of clean, cool and dry air is required for all air-cooled chiller appliances during normal operation and allows the chiller to operate at maximum capacity.
- If the appliance is placed in a location with floor void(s) below (such as false floors, drains or cable pathways etc.), precautions must be made to either seal the void(s) or supply adequate low-level ventilation. In particular, precautions should be made against refrigerant collecting in drains.
- If the appliance is placed in a machinery room with the increased risk of sources of ignition, it is advised that a refrigerant leak detector and a mechanical low-level ventilation system exhausting to an external atmospheric safe area is installed.
- Ensure all operatives are aware the appliance contains a flammable, odourless refrigerant.
- The ventilation system should be configured to be automatically activated upon detection of a refrigerant leak or set to continuously operate.
- Keep ventilation openings of the appliance enclosure or the structure of built in equipment clear of obstruction.

Document	M-007	Version	1.5	Date	19/06/25	Author	JWB	Page	8
----------	-------	---------	-----	------	----------	--------	-----	------	---

WARNING



- Always ensure appropriate fire extinguishers are placed at entrances and exits to the room housing the appliance(s) and adequate warning signage is installed to local laws/site requirements.
- Locate all refrigerant containing machinery so that damage from external sources would be highly unlikely.
- Should a suspected leak become apparent, immediately evacuate the area and **remotely** switch off the appliance if safe to do so.
- If a leak is suspected **DO NOT** disconnect the plug from the main supply socket or from the appliance inlet as this could act as a source of ignition. Leaking refrigerant may ignite and cause injuries.
- The appliance must be disconnected from its power source during cleaning; when maintenance and the replacement of parts is required, the equipment must be safely disconnected and isolated from the power supply using a lock-out system at the isolation device.
- It is advised that the electrical supply to the equipment is protected by an appropriately selected Residual Current Device (RCD).
- If the supply cord is damaged, it must be replaced by a service engineer or other qualified person.
- Fixed wiring appliances (those not supplied with a plug) shall incorporate a switch disconnecter to meet the specification of IEC 60947; this is to be installed within the fixed wiring installation in accordance to the local wiring rules / regulations to provide all pole disconnection of the power supply.
- Do not substitute the current refrigerant for any other refrigerant. The refrigerant used will be labelled on the appliance.
- Water pressures of up to 10 Bar during operation
- Hot and cold surfaces are present during operation.
- Always ensure the unit is isolated before service. The product is protected from overcurrent by fuses and MCBs. Never bypass these components.
- During fault diagnostics and maintenance, it may be necessary to remove panels, which expose the operator to the dangers of pressurized systems, hot or cold pipes and electrical circuits. Only qualified personnel who are aware and equipped to deal with these systems should carry out such work.
- Under no circumstances leave the product unattended with any panels/covers removed
- Any temporary electrical supply to the chiller should be correctly earthed and connected through an earth leakage trip.
- Never alter settings of pressure switches, overloads, circuit breakers or any safety device without first consulting Applied Thermal Control.

Document	M-007	Version	1.5	Date	19/06/25	Author	JWB	Page	9
----------	-------	---------	-----	------	----------	--------	-----	------	---

CAUTION



- Always wear appropriate PPE when performing routine maintenance. It is advised that suitable gloves and eye protection are used as a minimum requirement.
- Process fluid circuits connected to the appliance are designed to safely release/bypass abnormal pressure. There will be no possibility for the release of flammable refrigerant in this scenario.
- The pressure relief valve is factory-set and there is no provision for adjustment by the end-user
- Marking and signage to the equipment must continue to be visible and legible. Marking and signs that are illegible shall be corrected.
- The appliance is to be located in a position where it is not likely to be exposed to any substance that may corrode refrigerant containing components, unless the manufacturer has explicitly supplied components are constructed of materials which are inherently resistant to being corroded, or are suitably protected against being so corroded.

2.WASTE DISPOSAL

This product uses R290 refrigerant and compressor oil. Follow local regulations regarding the recovery and disposal of these substances. Refrigerant recovery must be completed by personnel qualified in the handling of hydrocarbon refrigerants.

Once oil and refrigerant are removed, the product must be handled as industrial waste in accordance with local regulations.

Document	M-007	Version	1.5	Date	19/06/25	Author	JWB	Page	10
----------	-------	---------	-----	------	----------	--------	-----	------	----



2.4 MODEL NUMBERING

The model number of your ATC product can guide you to the sections of the manual specific to your model. The model number can be found on the serial plate of the product, similar to the below.

Applied Thermal Control Ltd
 39 Hayhill Industrial Estate
 Barrow-upon-Soar, Loughborough
 LE12 8LD, United Kingdom

+44 (0) 1530 839 998
 support@app-therm.com

Model No: MG0503x
Refrigerant: R290 (GWP=3)
Charge: 90g (270g CO2e)
Max Pressure: 24 Bar / 348 PSI
Working. Pressure: 12 Bar / 174 PSI
Process Max Flow: 3 lpm
Process Max Pressure: 8 Bar / 120 PSI
Serial No: 2xxxxxx



VOLTS	Ph	Hz	MCA	FUSE	BCSC	COMPRESSOR		
						RLA	LRA	MOC
100-127V	1	60	-	4A	N/A	N/A	N/A	6.5A

If the model number format shown below does not match the model number on the product serial plate, this manual may not be applicable to your product. Electronic copies of all standard product manuals are located on our website. If you have a non-standard product or require any further assistance with manuals, please contact us.

User & Operation Manual

MG-SERIES CHILLERS

Document	M-007	Version	1.5	Date	19/06/25	Author	JWB	Page	11
----------	-------	---------	-----	------	----------	--------	-----	------	----

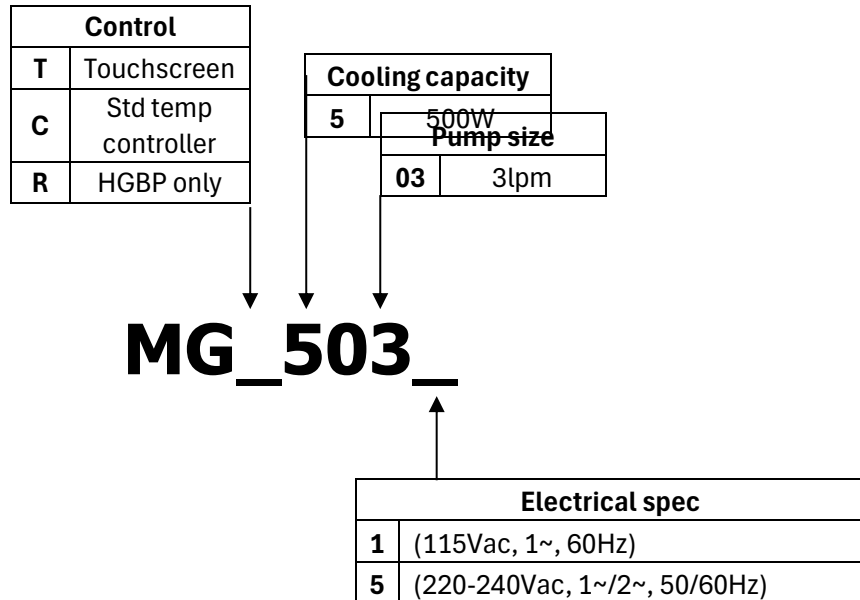

2.5 UNPACKING UNITS

Please check that both the packaging and the unit are undamaged. If there is any doubt, it is vital that you inform both ATC and the carrier. There are no hidden shipping bolts or other fixings. You should inspect the packaging for signs of transit damage before signing for the unit, and if possible, unpack the unit before signing. Once you have signed for the goods, ATC cannot be held responsible for any transit damage subsequently found.

This mass of this unit is within manual handling limits of a two-person lift. Safe manual handling practices must be adhered to.

Remove the unit from its original packaging and ensure that there is no packaging left around the cooling ducts. There is no internal product packaging that requires the chiller to be opened.

Please retain all packaging in the unlikely event that the chiller needs to be returned to our local representatives.

2.6 SITE REQUIREMENTS

1	Storage temperature range. Without process fluids, -20°C to +70°C.
2	Storage humidity range. Non-condensing, relative humidity 5% to 95%. Before starting product, allow product to acclimate for 24h in location of use when storing outside <i>operating</i> humidity range.
3	Operating temperature range. With appropriate process fluids,

User & Operation Manual

MG-SERIES CHILLERS

Document	M-007	Version	1.5	Date	19/06/25	Author	JWB	Page	12
-----------------	-------	----------------	-----	-------------	----------	---------------	-----	-------------	----

	Standard Unit: +4°C to +35°C Extended: -10°C to +55°C
4	Operating humidity range. 80% for ambient temperatures up to +31°C (+88°F), decreasing linearly to 50% relative humidity at +40°C (+104°F) ambient temperature.
5	Hard, level surface. A level surface is important for ensuring proper filling and allowing air to escape.
6	Electrical supply. The Internal fusing for a standard unit is rated at 10 Amps. If options such as heaters are added, this may increase. The current draw for your specific unit will be confirmed on the serial plate of your unit. For details on the required electrical supply, see production specification section 3.1 MG-SERIES (ALL STANDARD VARIANTS).
8	Clearance. Clearance is required to: <ol style="list-style-type: none"> Provide unobstructed access to the electrical panel to use power switch in case of emergency. Fit hoses and electrical supply to the rear of the unit allowing recommended bending radii. Allow maintenance access points and side panels to be removed. Allow process to take place – all models require the coolest, cleanest air that can be provided to achieve the best performance. This model draws air in from the left and right-hand sides (when viewing from the front of the unit) and rejects heated air to the rear. 0.5m clearance is recommended on air-on and air-off sides. Do not cover any vents.
9	Plumbing. Tubing, piping or hose must be clean and compatible with the fluid to be used. The product is compatible with water-glycol mixtures such as Hexid A4 and A6. Ensure the connected pipework is suitable for handling the nominal flowrate at system pressure of around 2 bar.
10	Indoor use only. Altitude up to 2000m above sea level. Ensure the unit has adequate ventilation. It is suggested the unit is located on a suitable workbench to provide an ergonomic working height.

CAUTION

	<ul style="list-style-type: none"> Always use ATC recommended fluids in our products – many sealing compounds and materials are present and unapproved fluids have the potential to corrode your application and damage seals. Do not use inadequately rated wiring. Consult an electrician if you are unsure. The safety of any system incorporating the equipment is the responsibility of the assembler of the system Do not replace detachable mains cords with inadequately rated cords. Contact ATC for appropriately rated products.
---	---

Document	M-007	Version	1.5	Date	19/06/25	Author	JWB	Page	13
----------	-------	---------	-----	------	----------	--------	-----	------	----

2.7 WARRANTY REGISTRATION

Please visit the website warranty registration page to ensure ATC can offer you the best possible support.

<https://www.app-therm.com/warranty-registration/>

a) **I'm experiencing problems with my chiller. It's within warranty – what do I do next?**

Contact ATC to discuss the issue you are having on +44(0)1530 839998 or support@app-therm.com. Be sure to have your model number and serial number on-hand to aid those attempting to solve remotely.

b) **Telephone support couldn't fix my chiller – what do I do next?**

An RMA form must be completed. This allows both the end-user and ATC to clarify your details, to set the party responsible for shipping costs, and to set a different return address if desired. Shipping advice is provided, and the end-user must sign a declaration that states the unit is safe to handle. Return the form by email for fastest response.

c) **What happens if my chiller failed outside warranty or requires non-warranty repair work?**

A purchase order will be requested to cover an initial inspection – this will only be invoiced if the inspection shows there is no fault. If packaging is required, i.e. a crate, a separate charge will be levied. If the end user prefers ATC to arrange a collection, a shipping charge may be levied.

d) **Our process must continue running – can we have a loan unit whilst our chiller is in repair?**

ATC hold several standard air-cooled chillers at the factory for the sole purpose of offering for loan. These are available on a first come, first-serve basis. Models up-to 3kW capacity are available.

Document	M-007	Version	1.5	Date	19/06/25	Author	JWB	Page	14
----------	-------	---------	-----	------	----------	--------	-----	------	----

3.0 PRODUCT SPECIFICATIONS

3.1 MG-SERIES (ALL STANDARD VARIANTS)

Weight	30Kg
Form factor	Bench mounting recommended
Dimensions	W220 x D516 x H428mm W8.66 x D20.32 x H16.85"
Noise level	65dB(A)@1m
Toolless access	No
Technology	Vapour compression
Cooling capacity (Ambient temperature at +20°C)	0.5 kW 1,706 BTU/h 0.142 TR
Refrigerant	R290
Refrigerant charge	90g
Ambient temperature range (operating)	0°C to +35°C
Maximum ambient (transport/storage)	70°C
Control method	MGT & MGC models: PID via solenoid valve MGR models: HGBP only
Stability	±0.1°C @ 500W Load
Resolution	0.1°C
Sensor type	MGT & MGC models: PT100 MGR models: None
System volume	0.7L
Pump (As per model number configuration)	24V brushless centrifugal, 3L/m
Pressure relief	None
Process fittings	12mm Push-fit
Electrical supply (As per model number configuration)	1-Spec: 100-127V ±5% (50/60Hz) 1~, 4.5A (Fused 6.3A) 5-Spec: 220-240V ±5% (50/60Hz) 1~, 4.5A (Fused 6.3A)
1 st party approvals	CE, UKCA
3 rd party approvals	[Pending]
Empty fluid tank alarm	Visual on-screen with touchscreen option
Low fluid flow alarm	None
Temp range alarm	Visual on-screen with touchscreen option
Fridge HP switch	Standard
Motor thermal cutout	None
Overcurrent protection	Standard, fused
Overcurrent restart	Manual

User & Operation Manual

MG-SERIES CHILLERS

Document	M-007	Version	1.5	Date	19/06/25	Author	JWB	Page	15
----------	-------	---------	-----	------	----------	--------	-----	------	----

Emergency off	Not present
Warranty options	2-year parts, 1-year labor Enhanced on request
Rated duty cycle	S1 Continuous

4.0 QUICK START GUIDE

1	Remove all the packaging (Section 1.3)
2	Connect chiller's outlet and inlet process to your application
3	Fill up the chiller with appropriate coolant
4	Use the name plate on the back of the chiller to verify the appropriate voltage and supply the power using provided cables.
5	Turn the power switch ON
6	Slowly add more coolant as process lines fill and the coolant is circulated around the process system.
7	Using the controller, set the desired temperature.

5.0 INSTALLATION

5.1 HOSE RECOMMENDATIONS

Having ensured that your installation meets all site requirements, it is best practice that the fluid lines between your application and the chiller have the following characteristics.

1	Short in length – this reduces friction-based pressure drop and addition ambient heat load.
2	Large diameter bore – at least 9.5mm (3/8”).
3	Free from 90° bends – to limit the effects of water hammer. If this cannot be avoided, sharp changes of direction should be minimized so far as possible. Doing this correctly can yield higher pump performance and extend time between maintenance intervals. It will also reduce electrical energy consumption.
4	Clean – If your installation is to existing pipe work, it is good practice to flush the system with either a commercially available central heating cleaner or 5% acetic acid solution. The system should be flushed clean to remove all traces of cleaner prior to filling the system. Failing this, it is recommended to use a domestic bleach in 1:1000 solution with water.
5	Opaque, ideally black – to inhibit light passing through the tube and algae building up. Alternatively, solid ABS or copper pipe can be used where application chemistry allows.
6	Insulation, where low temperature process is planned – the process line from chiller to application contains the feed of low temperature fluid. Insulation prevents heat from entering this line and can promote better stability. Uninsulated return lines are helpful where free cooling can be obtained by allowing heat to transfer to air – likewise, insulating the return line is helpful if the fluid temperature is below ambient.

User & Operation Manual

MG-SERIES CHILLERS

Document	M-007	Version	1.5	Date	19/06/25	Author	JWB	Page	16
----------	-------	---------	-----	------	----------	--------	-----	------	----

CAUTION



Never use transparent tubing. UV light will pass through, prompting growth of organic contamination.

5.2 FLUID FITTINGS

1	Ensure the appropriate thread sealants are used in the fitting of adapters to hose. For metallic mating parts, we recommend Loctite 577. For plastic adaptors such as those supplied with the product, we recommend using ~8-12mm wide PTFE tape, wrapped around the male thread before tightening.
2	Ensure that the system is correctly connected. The 'donut' labels around the ports are clearly marked with inlet and outlet symbols and function in both English and French language. Ports marked as outlet means fluid leaves the product and must be connected to the process inlet.
3	Check all joints are tight and leak free.
4	Where this product is incorporated into other equipment, it is the responsibility of the assembler to ensure safety

5.3 BACKFILLING

CAUTION



- In situations where the chiller is situated physically lower than the application being cooled, fluid will apply pressure to the water circuit of the product.
- The weakest seal is normally the tank lid, and this is typically where fluid will escape the unit.
- Ideally, the product will be located higher or level with the product waterline. If this is not possible, a non-return solenoid valve kit can be installed as an optional standard assembly.
- Please raise any questions with the sales team on sales@app-therm.com.

5.4 VOLTAGE SELECTION

CAUTION



- Different chillers will have different requirement for electrical supply. The specification and requirement can be found on the back plate of the chiller.
- Please ensure that the voltage supply and number of phases are correct on the site and your power supply can handle the stated current draw.
- Where key-switch voltage selectors are fitted, check these have been correctly set to match your electrical supply.

Document	M-007	Version	1.5	Date	19/06/25	Author	JWB	Page	17
----------	-------	---------	-----	------	----------	--------	-----	------	----

5.5 FILLING PROCEDURE

a) Check all application valves are open, including solenoid valves and variable position valves.

- i) The product will require an open water circuit to pump into.
- ii) Any obstructions can increase the time, or entirely prevent the bleeding of air from the system.

b) Remove the cap from the tank lid on the top of the product.

- i) Fill the tank until fluid is visible at the centre of the tank sight glass. This is the maximum fill level.

c) Switch the unit on

- i) Check power is connected and switched on.
- ii) Switch the unit on at the rocker switch. The pump will start running immediately.
- iii) Keep the unit running until the water level in the tank drops and cuts out on the level switch interlock.
- iv) Turn the unit off at the main switch.
- v) Fill the tank again to lift the level switch.
- vi) Start the product

CAUTION



CAUTION: Do not run the pump dry.

d) Repeat step (c) until the chiller does not cut out on the level switch.

e) Now with the unit running:

- i) Leave the cap off the tank for 20-30mins to allow air to escape, or very loosely screwed on to prevent dust & debris ingress.

f) Check the application and tubing for signs of leaks whilst the chiller is running.

- i) Replace the tank lid fully when satisfied the system is full and bled of air and no abnormal sound can be heard from the pump

Document	M-007	Version	1.5	Date	19/06/25	Author	JWB	Page	18
-----------------	-------	----------------	-----	-------------	----------	---------------	-----	-------------	----

5.6 DRAINING A SYSTEM

- a) Isolate the unit. Have a suitable receptacle or drain on-hand.
 - i) Remove the tank lid to allow air into the system.
 - ii) Disconnect hoses individually. Be aware hoses as well as the unit are filled with fluid.
 - iii) Use tank drain tap (where fitted).
 - iv) Consider using the red transport plugs to block product ports to give yourself time to empty hoses before continuing to empty the product.

- b) Local rules affect where fluid can be disposed of.

Ensure hazardous products do not enter the water course and are reclaimed from the unit for professional disposal.





Document	M-007	Version	1.5	Date	19/06/25	Author	JWB	Page	19
----------	-------	---------	-----	------	----------	--------	-----	------	----

6.0 CONTROLLER OPERATION

Controllers are fitted to all MGT & MGC models. MGR models provide a fixed cooling output, and as such do not have a controller, MGR models can be fitted with an optional temperature display. EMG models are adjusted at the hot-gas bypass only, for more information refer to the Maintenance manual.

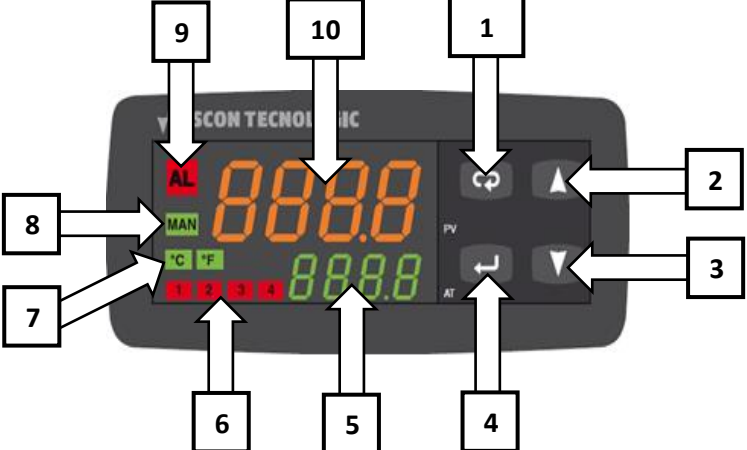
6.1 KR1 CONTROLLER – MGC MODELS













The KR1 is a high performance PID controller, which can control temperature to within 0.1 °C of set point. In addition, there is a high and low temperature WARNING via the LED on the display of the controller, which is triggered if the temperature deviates more than 10 °C from the set point.

DISPLAY CONTENTS DURING NORMAL OPERATION	
	
1	Menu navigation button: Return
2	Menu navigation button: Up
3	Menu navigation button: Down
4	Menu navigation button: Enter
5	Setpoint value (SP) display, set by user.
6	Active output (1-4) display
7	°C or °F temperature unit display, settable in the 'inP' group.
8	Manual mode enabled display (fixed output value).
9	Alarm active display. This appears when output is beyond the set alarm point.
10	Present value (PV) display, from input sensor.
ACCESS TO SETTINGS	
1	Press and hold  for more than 5 seconds. The Present Value display [10] will show PASS while the Setpoint display [5] will show 0.
2	Using  and  buttons, set the programmed password – full access is granted by entering '40'. ATC are not responsible for damage either to the chiller or the connected equipment as a result of changing parameters without consulting ATC.





User & Operation Manual

MG-SERIES CHILLERS

Document	M-007	Version	1.5	Date	19/06/25	Author	JWB	Page	20
-----------------	-------	----------------	-----	-------------	----------	---------------	-----	-------------	----

3	<p>During parameter modification the instrument continues to perform process control. In certain conditions, when a configuration change can produce a significant change to the process, it is advisable to temporarily stop the controller from controlling during the programming procedure (control outputs [6] will be OFF).</p> <p>A password equal to 2000 + the programmed value (i.e. 2000 + 40 = 2040). The control will restart automatically when the configuration procedure will be manually closed.</p>
4	<p>Press  If the password is correct the display, will show the acronym of the first parameter group 'inP'. Press and hold  for more than 5 seconds, then the instrument will come back to the "standard display".</p>
5	<p>The configuration parameters are collected in various groups. Every group defines all parameters related with a specific function (control, alarms, output functions).</p>
6	<p>Press and hold  for more than 5 seconds, the instrument will come back to the "standard display". For specific settings and guidance, review the controller datasheets provided by ATC. If you are not in receipt of these, please contact ATC using the information in the header of this document.</p>
GENERAL NAVIGATION	
	<p>A short press allows you to exit from the current parameter group and select a new parameter group. A long press allows you to close the configuration parameter procedure (the instrument will come back to the "standard display").</p>
	<p>When the upper display is showing a group and the lower display is blank, this key allows you to enter the selected group. When the upper display is showing a parameter and the lower display is showing its value, this key allows to store the selected value for the current parameter and access the next parameter within the same group.</p>
	<p>Allows to increase the value of the selected parameter.</p>
	<p>Allows to decrease the value of the selected parameter.</p>
 	<p>Pushing both  and  moves back to the previous group. Press and hold  first, then also press and hold  The selection of the group is cyclic (on a carousel), so it is possible to move back around to the group you require.</p>

6.1.1 CHANGING SETPOINT

ACHIEVING DESIRED SET POINT	
1	Push and hold  until it shows "SP 1"
2	Use  and  to adjust the temperature setpoint
3	Press  again to confirm the new temperature setpoint
4	The set value now will be activated, and the chiller will start

User & Operation Manual

MG-SERIES CHILLERS

Document	M-007	Version	1.5	Date	19/06/25	Author	JWB	Page	21
----------	-------	---------	-----	------	----------	--------	-----	------	----

6.2 TOUCHSCREEN CONTROLLER – MGT MODELS

Annex E-17 Coolmay Mini Touchscreen

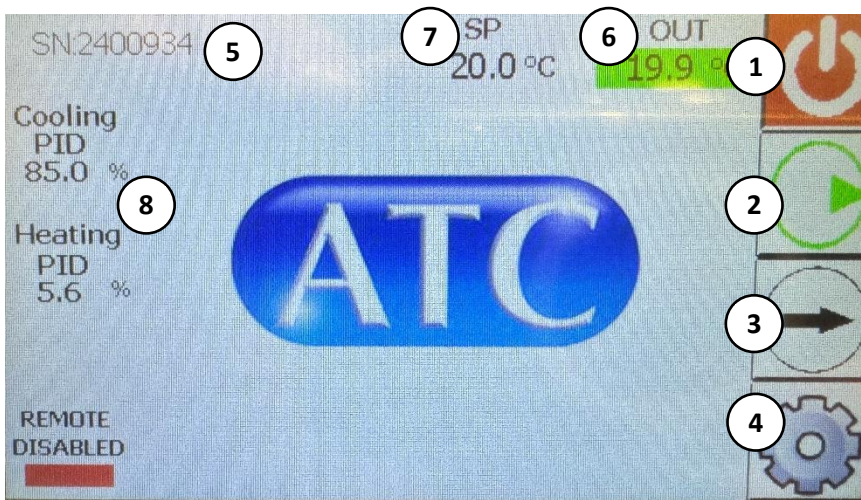

Splash Screen

Upon first powering on, the chiller will arrive at this page after a software loading sequence is complete.

1. Process start/stop (Start/stop fridge and water circuit).
2. Pump priming toggle button runs pump without process starting.
3. Next Page.
4. Access to settings menu. (See *Passcode Entry*)
5. Serial number is added by ATC during production.
6. Process outlet temperature. (Green = in range/Red = out of range).
7. Process Set Point.
8. PID Percentage outputs.

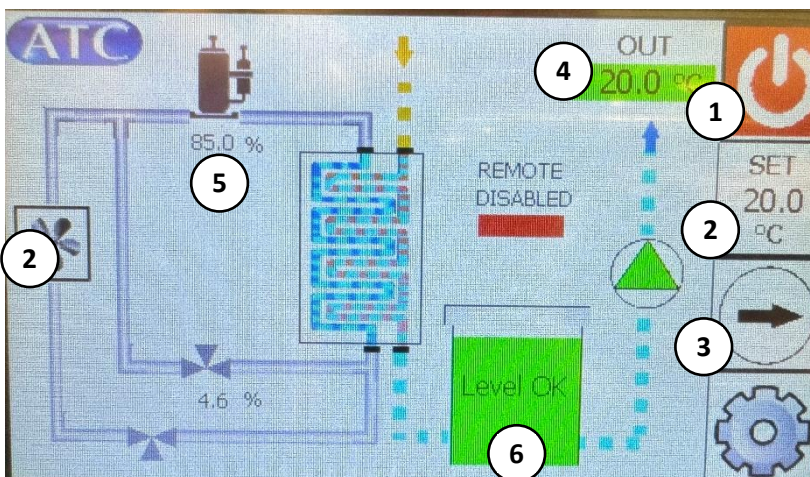

Process View

1. Process Start/Stop.
 2. Set outlet temperature.
 3. Next page.
 4. Process outlet temperature. (Green = in range/Red = out of range).
 5. Compressor utilization.
 6. Tank level status.
- Green = Full

User & Operation Manual

MG-SERIES CHILLERS

Document	M-007	Version	1.5	Date	19/06/25	Author	JWB	Page	22
----------	-------	---------	-----	------	----------	--------	-----	------	----

Amber = Top-up

Red = Low level (Chiller will automatically switch off to protect internal components)

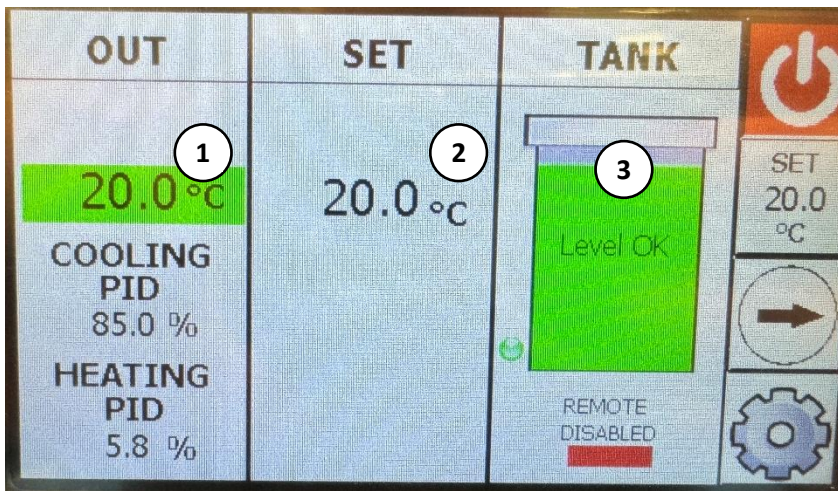

Simple View

1. Actual outlet temperature. (Green = in range/Red = out of range).

2. Setpoint temperature.

3. Tank level status.

6.3 REGULATING PRESSURE/FLOW

PRESSURE AND FLOW ADJUSTMENT IN MINI CHILLER WITH CENTRIFUGAL PUMP

The flow of the pump is dictated by the backpressure of the pipework. Reviewing the pump flow curve can indicate the expected flow. Centrifugal pumps have such a limited maximum pressure, that the water circuit components alone can hold the pressure, and no pressure relief valve is fitted. If further limitation of pressure is required, a flow control valve can be fitted to either the outlet or inlet of the chiller, depending on whether the application is to be pressurized or not.

Document	M-007	Version	1.5	Date	19/06/25	Author	JWB	Page	23
----------	-------	---------	-----	------	----------	--------	-----	------	----

7.0 BASIC TROUBLESHOOTING

#	SYMPTOM	CAUSES
1	Compressor or pump motor not running, control illuminated.	Level switch may have been tripped – Fill the tank up again to resolve the issue
		High pressure switch may have been tripped: <ul style="list-style-type: none"> a) Assess whether the ambient temperature is too high. b) Assess whether ventilation/air circulation is poor. c) Assess whether surrounding equipment is generating hot air and feeding it into the chiller air intakes.
		If fitted, a low-pressure switch may have tripped – this indicates refrigerant loss. A multimeter is required to test this.
		If running at a high setpoint, or if operating conditions have changed and raised the fluid temperature, it is possible the compressor has turned itself on high temperature internal protection.
		Air-cooled models only: Check fan spins freely and that condenser is clear of debris.
		Water-cooled models only: <ul style="list-style-type: none"> a) Check for sufficient flowrate and pressure of house water. b) Assess whether the house water temperature is too high. c) Assess whether any fouling of condenser plate heat exchanger has occurred. d) Assess whether new equipment has been added to a shared water supply and contributed to either a lack of water flow (through flow splitting) or whether additional thermal load has been added to the central water's chiller/cooler
2	Noisy Operation	Pump motor or fan motor bearings may have failed.
		Pump head vane or seal may have failed.
		In a 3-phase system, phase rotation may be incorrect.
3	High fluid pressure/low flow rate	Fluid lines may have become fouled through solid debris or biological growth. <ul style="list-style-type: none"> a) Ensure biocides or pre-mixed biocidal process fluids are being used. b) Ensure hoses are not transparent or translucent – UV light entering prompts growth.
		General fluid leak can lead to flow rate failure.
		Excess fittings, too many sharp direction changes, too small a diameter hose for flowrate or hoses too long at the wrong diameter.
4	Fluid collecting or leaking	Leaks are impossible to diagnose remotely, but usually you will see a pool of fluid on a lower surface. Do not confuse this with condensation from cold parts of the fridge.
		Review the chemical compatibility of your fluid with the chiller. Contact ATC if you are unsure.
5	Poor Cooling Performance	Excess thermal load applied <ul style="list-style-type: none"> a) Assess whether the ambient temperature is too high.

User & Operation Manual

MG-SERIES CHILLERS

Document	M-007	Version	1.5	Date	19/06/25	Author	JWB	Page	24
-----------------	-------	----------------	-----	-------------	----------	---------------	-----	-------------	----



	<ul style="list-style-type: none">b) Assess whether ventilation/air circulation is poor.c) Assess whether surrounding equipment is generating hot air and feeding it into the chiller air intakes.
	Air-cooled models only: <ul style="list-style-type: none">d) Check if the fans are running.e) Clean the condenser coil.
	Water-cooled models only: <ul style="list-style-type: none">d) Assess whether house water temperature is too high.e) Assess whether house water flowrate is too low.
Please contact ATC if you could not find the information you were looking for or still have an issue with the unit	

User & Operation Manual

MG-SERIES CHILLERS





Document	M-007	Version	1.5	Date	19/06/25	Author	JWB	Page	25
----------	-------	---------	-----	------	----------	--------	-----	------	----

8.0 END USER MAINTENANCE

⚠ WARNING												
	Safely isolate your product prior to commencing any cleaning or maintenance tasks.											
CAUTION												
	<ul style="list-style-type: none"> • Failure to carry out service at the specified intervals may permanently damage your equipment. • Never blow out the condenser with compressed air (air-cooled units only). • If the main lead is lost or damaged, contact ATC who will be able to supply a replacement to the correct specification. • It is recommended that a full service and refrigerant circuit leak test of the appliance is conducted every 6 months by engineers qualified in the handling of hydrocarbon refrigerants. 											
Print this sheet out and display close to the chiller to maximize the visibility of maintenance requirements.												
Weekly	Week 1	Week 2	Week 3	Week 4								
Check Fluid Level – Top up as required												
Monthly	J	F	M	A	M	J	J	A	S	O	N	D
<i>Air-cooled only:</i> Check the condenser is free from dust or accumulation of debris												
Annually	Y1	Y2	Y3	Y4	Y5	Y6						
Drain process fluid and replace with fresh fluid												
Check for fluid leaks throughout chiller and application												
Clear any debris from inside the chiller												
A vacuum cleaner is recommended for cleaning out the condenser (air cooled units only). Soft cloths and IPA are recommended for cleaning metallic surfaces. If any spillages have occurred, allow the water to evaporate and wipe up remaining glycol residue with a cloth.												

Document	M-007	Version	1.5	Date	19/06/25	Author	JWB	Page	26
----------	-------	---------	-----	------	----------	--------	-----	------	----

9.0 DECLARATION OF CONFORMITY

		
EU DECLARATION OF CONFORMITY / UK CONFORMITY ASSESSED		
Applied Thermal Control Ltd, 39 Hayhill Industrial Estate, Barrow-upon-Soar, Loughborough, LE12 8LD, UK. Tel +44 (0)1530 83 99 98. www.app-therm.com		
We hereby declare in sole responsibility that the following product;		
Product:	Recirculating Chiller	
Product range:	Prefix MG	
Serial number:	<input type="text"/>	
Is compliant with the following directives:	Machinery Directive 2006/42/EC EMC Directive 2004/108/EC Low Voltage Directive 2014/35/EU RoHS Directive 2011/65/EU ⁽¹⁾ <small>⁽¹⁾ Including substances added by Commission Delegated Directive (EU) 2015/863</small>	
Is compliant with the following harmonized standards:	EN ISO 12100:2010 General principles for design — Risk assessment and risk reduction EN 378-1:2016+A1:2020 Refrigerating systems and heat pumps. Safety and environmental requirements - Basic requirements, definitions, classification and selection criteria EN 378-2:2016+A1:2020 Refrigerating systems and heat pumps. Safety and environmental requirements - Design, construction, testing, marking and documentation EN 61010-1:2010+A1:2019 Safety requirements for electrical equipment for measurement, control, and laboratory use - General requirements IEC 61000-6-2:2005 Electromagnetic compatibility (EMC) - Immunity for industrial environments IEC 61000-6-4:2006 +A1:2011 Electromagnetic compatibility (EMC) - Emission standard for industrial environments	
Quality assurance system:	Citation ISO Certification, Muspole Court, Muspole Street, Norwich, NR3 1DJ, United Kingdom. ASCB Registered; 201409-2	
Authorized representative in charge of administering technical documentation:	Atik Cameras Unipessoal Lda. Rua Horta dos Bacelos, 15 2690-390 Santa Iria da Azoia Portugal	
Person empowered to draw up declaration:		
Place and date:	Barrow-Upon-Soar, UK, 19/06/2025	
Name and function:	Robert Poniatowski, Managing Director	

Document	M-007	Version	1.5	Date	19/06/25	Author	JWB	Page	27
-----------------	-------	----------------	-----	-------------	----------	---------------	-----	-------------	----

10.0 REFRIGERANT & HEAT TRANSFER FLUID SAFETY DATA SHEETS

Safety Data Sheets in the below sections for the refrigerant used in your product, along with ATC heat transfer fluids. For further information on which heat transfer fluid is best for your application, please contact Applied Thermal Control.

User & Operation Manual

MG-SERIES CHILLERS

Document	M-007	Version	1.5	Date	19/06/25	Author	JWB	Page	28
----------	-------	---------	-----	------	----------	--------	-----	------	----

10.1 R290 SAFETY DATA SHEET



SAFETY DATA SHEET REFRIGERANT R290

Page: 1

Compilation date: 17/02/2017

Revision No: 1a

Section 1: Identification of the substance/mixture and of the company/undertaking

1.1. Product identifier

Product name: REFRIGERANT R290

Product code: R290

Synonyms: REFRIGERANT GRADE PROPANE

1.2. Relevant identified uses of the substance or mixture and uses advised against

1.3. Details of the supplier of the safety data sheet

Company name: National Refrigerants Ltd
4 Watling Close
Sketchley Meadows Business Park
Hinckley
Leicestershire
LE10 3EZ
United Kingdom
Tel: 01455 630790
Fax: 01455 630791
Email: sds@nationalref.com

1.4. Emergency telephone number

Emergency tel: Carechem24 +44 (0)1865 407333

Section 2: Hazards identification

2.1. Classification of the substance or mixture

Classification under CLP: Flam. Gas 1: H220; Press. Gas: H280

Most important adverse effects: Extremely flammable gas. Contains gas under pressure; may explode if heated.

2.2. Label elements

Label elements:

Hazard statements: H220: Extremely flammable gas.

H280: Contains gas under pressure; may explode if heated.

Hazard pictograms: GHS02: Flame

GHS04: Gas cylinder



Signal words: Danger

Precautionary statements: P210: Keep away from heat, hot surfaces, sparks, open flames and other ignition

[cont...]

Document	M-007	Version	1.5	Date	19/06/25	Author	JWB	Page	29
----------	-------	---------	-----	------	----------	--------	-----	------	----

SAFETY DATA SHEET REFRIGERANT R290

Page: 2

sources. No smoking.

P377: Leaking gas fire: Do not extinguish, unless leak can be stopped safely.

P381: In case of leakage, eliminate all ignition sources.

P403: Store in a well-ventilated place.

P410: Protect from sunlight.

2.3. Other hazards

Other hazards: In use, may form flammable / explosive vapour-air mixture.

PBT: This product is not identified as a PBT/vPvB substance.

Section 3: Composition/information on ingredients

3.2. Mixtures

Section 4: First aid measures

4.1. Description of first aid measures

Skin contact: Remove all contaminated clothes and footwear immediately unless stuck to skin.

Drench the affected skin with running water for 10 minutes or longer if substance is still on skin. Do not use hot water. If frostbite has occurred call a physician.

Eye contact: Bathe the eye with running water for 15 minutes. Consult a doctor.

Ingestion: Not applicable.

Inhalation: Remove casualty from exposure ensuring one's own safety whilst doing so. If unconscious, check for breathing and apply artificial respiration if necessary. Consult a doctor.

4.2. Most important symptoms and effects, both acute and delayed

Skin contact: There may be redness or whiteness of the skin in the area of exposure. Frost-bite may occur causing the affected area to become white and numb.

Eye contact: There may be pain and redness. Corneal burns may occur. May cause permanent damage.

Ingestion: Not applicable.

Inhalation: There may be drowsiness, slurred speech, muscular weakness, muscle twitching, tremor, blurred vision, dilated pupils and shock.

4.3. Indication of any immediate medical attention and special treatment needed

Immediate / special treatment: Not applicable.

Section 5: Fire-fighting measures

5.1. Extinguishing media

Extinguishing media: Alcohol resistant foam. Water spray. Carbon dioxide. Dry chemical powder. Suitable extinguishing media for the surrounding fire should be used. Use water spray to cool containers.

[cont...]

Document	M-007	Version	1.5	Date	19/06/25	Author	JWB	Page	30
----------	-------	---------	-----	------	----------	--------	-----	------	----

SAFETY DATA SHEET

REFRIGERANT R290

Page: 4

DNEL/PNEC Values

DNEL / PNEC No data available.

8.2. Exposure controls

Engineering measures: Ensure there is sufficient ventilation of the area. Ensure lighting and electrical equipment are not a source of ignition.

Respiratory protection: Respiratory protection not required.

Hand protection: Protective gloves.

Eye protection: Safety glasses with side-shields. Safety goggles. Face-shield. Ensure eye bath is to hand.

Skin protection: Protective clothing.

Section 9: Physical and chemical properties

9.1. Information on basic physical and chemical properties

State: Liquified gas

Colour: Colourless

Odour: Characteristic odour

Boiling point/range°C: -42.1

Flammability limits %: lower: 2.2

upper: 9.5

Autoflammability°C: 470

Vapour pressure: 8.3 Bar @ 20oC

Relative density: 1.5 (Air=1)

9.2. Other information

Other information: No data available.

Section 10: Stability and reactivity

10.1. Reactivity

Reactivity: Stable under recommended transport or storage conditions.

10.2. Chemical stability

Chemical stability: Stable under normal conditions. Stable at room temperature.

10.3. Possibility of hazardous reactions

Hazardous reactions: Hazardous reactions will not occur under normal transport or storage conditions.

Decomposition may occur on exposure to conditions or materials listed below.

10.4. Conditions to avoid

Conditions to avoid: Heat. Hot surfaces. Sources of ignition. Flames.

10.5. Incompatible materials

Materials to avoid: Strong oxidising agents. Strong acids.

10.6. Hazardous decomposition products

Haz. decomp. products: In combustion emits toxic fumes.

[cont...]

Document	M-007	Version	1.5	Date	19/06/25	Author	JWB	Page	31
----------	-------	---------	-----	------	----------	--------	-----	------	----

SAFETY DATA SHEET
REFRIGERANT R290

Page: 5

Section 11: Toxicological information

11.1. Information on toxicological effects

Toxicity values: No data available.

Symptoms / routes of exposure

Skin contact: There may be redness or whiteness of the skin in the area of exposure. Frost-bite may occur causing the affected area to become white and numb.

Eye contact: There may be pain and redness. Corneal burns may occur. May cause permanent damage.

Ingestion: Not applicable.

Inhalation: There may be drowsiness, slurred speech, muscular weakness, muscle twitching, tremor, blurred vision, dilated pupils and shock.

Section 12: Ecological information

12.1. Toxicity

Ecotoxicity values: No data available.

12.2. Persistence and degradability

Persistence and degradability: Biodegradable.

12.3. Bioaccumulative potential

Bioaccumulative potential: No bioaccumulation potential.

12.4. Mobility in soil

Mobility: Readily absorbed into soil.

12.5. Results of PBT and vPvB assessment

PBT identification: This product is not identified as a PBT/vPvB substance.

12.6. Other adverse effects

Other adverse effects: * Ozone Depletion Potential (ODP): 0 (R11 = 1) R290: Global Warming Potential (GWP): 3 (CO2=1)

Section 13: Disposal considerations

13.1. Waste treatment methods

Disposal operations: Product evaporates.

Recovery operations: Consult manufacturer or supplier for information regarding recovery and recycling of the product. If recovery is not possible, incinerate at a licensed installation.

Waste code number: 16 05 05

Disposal of packaging: Return to supplier.

NB: The user's attention is drawn to the possible existence of regional or national regulations regarding disposal.

[cont...]

Document	M-007	Version	1.5	Date	19/06/25	Author	JWB	Page	32
----------	-------	---------	-----	------	----------	--------	-----	------	----

SAFETY DATA SHEET REFRIGERANT R290

Page: 6

Section 14: Transport information

14.1. UN number

UN number: UN1978

14.2. UN proper shipping name

Shipping name: PROPANE

14.3. Transport hazard class(es)

Transport class: 2

14.4. Packing group

14.5. Environmental hazards

Environmentally hazardous: No

Marine pollutant: No

14.6. Special precautions for user

Special precautions: No special precautions.

Tunnel code: B/D

Transport category: 2

Section 15: Regulatory information

15.1. Safety, health and environmental regulations/legislation specific for the substance or mixture

Specific regulations: Not applicable.

15.2. Chemical Safety Assessment

Chemical safety assessment: A chemical safety assessment has not been carried out for the substance or the mixture by the supplier.

Section 16: Other information

Other information

Other information: This safety data sheet is prepared in accordance with Commission Regulation (EU) No 2015/830.

* indicates text in the SDS which has changed since the last revision.

Phrases used in s.2 and s.3: H220: Extremely flammable gas.

H280: Contains gas under pressure; may explode if heated.

Legal disclaimer: National Refrigerants Ltd believes that the information and recommendations contained herein (including data and statements) are accurate as of the date hereof. NO WARRANTY OF FITNESS FOR ANY PARTICULAR PURPOSE, WARRANTY OF MERCHANTABILITY, OR ANY OTHER WARRANTY, EXPRESSED OR IMPLIED, IS MADE CONCERNING THE INFORMATION PROVIDED HEREIN. The information provided herein relates only to the specific product designated. The information may not be valid where such product is used in combination with any other methods of use of the product

[cont...]

User & Operation Manual

MG-SERIES CHILLERS

Document	M-007	Version	1.5	Date	19/06/25	Author	JWB	Page	33
----------	-------	---------	-----	------	----------	--------	-----	------	----

SAFETY DATA SHEET

REFRIGERANT R290

Page: 7

and the information referred to herein are beyond the control of National Refrigerants Ltd. National Refrigerants expressly disclaims any and all liability as to any results obtained or arising from any use of the product or reliance on such information.

[final page]



Document	M-007	Version	1.5	Date	19/06/25	Author	JWB	Page	34
----------	-------	---------	-----	------	----------	--------	-----	------	----

10.2 HEXID A4 SAFETY DATA SHEET

<p>Applied Thermal Control Ltd 39 Hayhill Industrial Estate Barrow upon Soar, Leicestershire LE12 8LD, United Kingdom</p>		<p>SAFETY DATA SHEET HEXID A4 HEAT TRANSFER FLUID Conforming to Directive 1907/2006/EC</p>			
Issue	6.7	Date	April 2025	Page	1
SECTION 1: IDENTIFICATION OF THE SUBSTANCE/MIXTURE AND OF THE COMPANY/UNDERTAKING					
1.1	Product Name	Hexid A4			
1.2	Intended/Recommended Use	Heat Transfer Fluid			
1.3	Manufacturer	Applied Thermal Control Limited 39 Hayhill Industrial Estate, Barrow upon Soar, Leicestershire, LE12 8LD, United Kingdom. www.app-therm.com			
1.4	Emergency Telephone Number	+44(0)1530 839998			
1.5	Email	sales@app-therm.com			
SECTION 2: HAZARDS IDENTIFICATION					
2.1	Classification of the substance or mixture	The product is not classified as dangerous according to Regulation (EC) No. 1272/2008. This mixture is not classified as dangerous according to Directive 1999/45/EC. This mixture has no classification under CLP			
2.2	Label elements	Label elements: This product has no label elements Signal Word: No signal word. Hazard statements: No known significant effects or critical hazards. Precautionary statements: Prevention, Response, Storage or Disposal: Not applicable.			
2.3	Other hazards	PBT: This product is not identified as a PBT/vPvB substance.			
SECTION 3: COMPOSITION/INFORMATION ON INGREDIENTS					
3.1	Chemical Nature	Water (CAS 7732-18-5), not classified. Propylene glycol (CAS 57-55-6) (REACH 01-2119456809-23) (EINECS 200-338-0) not classified. Fluorescein (trace) and biocide (trace) not classified.			
3.2	Food Grade	Food Grade			
SECTION 4: FIRST AID MEASURES					
General advice		No special precautions required. Treat symptomatically.			
4.1	Eye Contact	Rinse thoroughly with plenty of water, also under the eyelids. Remove contact lenses after a few minutes and continue rinsing. If symptoms persist, call a physician.			
4.2	Skin Contact	Wash off immediately with plenty of water. If skin irritation persists, call a physician.			
4.3	Inhalation	Remove to fresh air. If symptoms persist, call a physician.			
4.4	Ingestion	Rinse mouth with water. Never give anything by mouth to an unconscious person. If symptoms persist, call a physician.			

Document	M-007	Version	1.5	Date	19/06/25	Author	JWB	Page	35
----------	-------	---------	-----	------	----------	--------	-----	------	----

Applied Thermal Control Ltd
39 Hayhill Industrial Estate
Barrow upon Soar, Leicestershire
LE12 8LD, United Kingdom

SAFETY DATA SHEET HEXID A4 HEAT TRANSFER FLUID Conforming to Directive 1907/2006/EC



Issue	6.7	Date	April 2025	Page	2
-------	-----	------	------------	------	---

SECTION 5: FIREFIGHTING MEASURES

5.1	Extinguishing media	Use extinguishing measures that are appropriate to local circumstances and the surrounding environment. Water spray, foam, dry powder or CO2. Alcohol-resistant foam
5.2	Unsuitable extinguishing Media	High volume water jet. Do not use a solid water stream as it may scatter and spread fire.
5.3	Specific hazards during firefighting	In fire conditions, toxic decomposition products may be formed (see also section 10). In combustion, emits fumes, smoke, carbon dioxide (CO2) and carbon monoxide (CO). Heating will cause a pressure rise - with severe risk of bursting and explosion, Violent steam generation or eruption may occur upon application of direct water to hot liquids.
5.4	Advice for firefighters	In the event of fire, wear self-contained breathing apparatus. Wear personal protective equipment. Promptly isolate the scene by removing all persons from the vicinity of the incident if there is a fire. Keep containers cool by spraying with water if exposed to fire. Collect contaminated fire extinguishing water separately. This must not be discharged into drains. Burning fluids may be extinguished by dilution with water.

SECTION 6: ACCIDENTAL RELEASE MEASURES

6.1	Personal precautions	Use personal protective equipment. Avoid contact with skin and eyes. Keep unnecessary and unprotected personnel from entering the area.
6.2	Precaution to protect the environment	Do not flush into surface water or sanitary sewer system. Avoid subsoil penetration.
6.3	Clean-up procedures	Contain the spillage, soak up with non-combustible absorbent material, (e.g. sand, earth, diatomaceous earth, vermiculite) and transfer to a container for disposal according to local/national regulations (see section 13). Keep in suitable, closed containers for disposal. Dike the area of spill to prevent spreading and pump liquid to salvage tank. Treat recovered material as described in section 13 Disposal considerations.

SECTION 7: HANDLING AND STORAGE

7.1	Precautions for safe handling	Keep container tightly closed. Handle in accordance with good industrial hygiene and safety practice. Spills of these organic materials on hot fibrous insulations may lead to lowering of the auto-ignition temperatures possibly resulting in spontaneous combustion.
7.2	Conditions for safe storage	Keep only in the original container.

SECTION 8: EXPOSURE CONTROLS/PERSONAL PROTECTION

Document	M-007	Version	1.5	Date	19/06/25	Author	JWB	Page	36
----------	-------	---------	-----	------	----------	--------	-----	------	----

<p>Applied Thermal Control Ltd 39 Hayhill Industrial Estate Barrow upon Soar, Leicestershire LE12 8LD, United Kingdom</p>		<p>SAFETY DATA SHEET HEXID A4 HEAT TRANSFER FLUID Conforming to Directive 1907/2006/EC</p>			
Issue	6.7	Date	April 2025	Page	3
8.1	Control Parameters	<p>Component: Propane-1,2-diol CAS-No. 57-55-6 Other Occupational Exposure Limit Values EH40 WEL, Time Weighted Average (TWA): Total vapour and particulates.150 ppm, 474 mg/m³ EH40 WEL, Time Weighted Average (TWA): Particulate.10 mg/m³ ELV (IE), Time Weighted Average (TWA): Total vapour and particulates.150 ppm, 470 mg/m³ ELV (IE), Time Weighted Average (TWA): Particulate.10 mg/m³</p>			
8.2	Exposure controls/Appropriate engineering controls	<p>Local exhaust. If this product contains ingredients with exposure limits, use process enclosures, local exhaust ventilation or other engineering controls to keep worker exposure below any recommended or statutory limits.</p>			
	Personal protective equipment	<p>Respiratory protection: Suitable respiratory protective device Combination filter: A-P2 Filter Type: Combined particulates and organic vapour type Hand protection: Category short time exposure - Break through time> 10 min Protective index: Class 1 When prolonged exposure is expected: Break through time> 120 min Protective index: Class 4 Observe the information of the glove manufacturers on permeability. Protective gloves should be chosen according to Workplace Safety Assessment. Gloves recommended according to EN 374 (protection against chemicals). Material: Chemical resistant gloves made of butyl rubber or nitrile rubber category III according to EN 374.</p>			
SECTION 9: PHYSICAL AND CHEMICAL PROPERTIES					
9.1	Appearance at 20°C	Fluorescent green clear liquid			
9.2	Odour	Almost odourless			
9.3	Flash Point	Boils without flashing			
9.4	Ignition Temperature	Not available			
9.5	Flammability Limit	Not available			
9.6	Oxidizing Properties	Not available			
9.7	Auto flammability	450°C			
9.8	Density at 25°C	~1.036g/cm ³			
9.9	pH (as is)	9.4			
9.10	Boiling point	102°C			
9.11	Solubility in water	Miscible			
9.12	Freezing point	-21°C			
9.13	Specific Heat Capacity	3.78kJ/kg °K			
9.14	Viscosity, Kinetic, at 25°C	3.51mPas			

Document	M-007	Version	1.5	Date	19/06/25	Author	JWB	Page	37
----------	-------	---------	-----	------	----------	--------	-----	------	----

Applied Thermal Control Ltd
39 Hayhill Industrial Estate
Barrow upon Soar, Leicestershire
LE12 8LD, United Kingdom

SAFETY DATA SHEET

HEXID A4 HEAT TRANSFER FLUID

Conforming to Directive 1907/2006/EC



Issue	6.7	Date	April 2025	Page	4
-------	-----	------	------------	------	---

SECTION 10: STABILITY AND REACTIVITY

10.1	Reactivity	Stable under recommended storage conditions. No dangerous reaction known under conditions of normal use.
10.2	Chemical stability	No decomposition if stored and applied as directed. Stable under recommended storage conditions. Hygroscopic.
10.3	Hazardous reactions	Hazardous polymerisation does not occur.
10.4	Conditions to avoid	Generation of gas from decomposition causes pressure in closed systems. Keep away from direct sunlight. Avoid high temperatures. Avoid temperatures exceeding the decomposition temperature. Avoid UV light.
10.5	Materials to avoid	Strong acids, Strong bases, Strong oxidising agents.
10.6	Hazardous decomposition products	Aldehydes, Alcohols, Ether, Organic acids.

SECTION 11: TOXICOLOGICAL INFORMATION

11.1	Toxicity Oral	LD50: > 20000 mg/kg (rat) This product can present a small hazard if large quantities are swallowed.
11.2	Inhalation	LC50: 6.15 mg/l (rat; 4 h; vapour) At ambient temperature the exposure to vapours is minimal due to a low volatility rate. Inhalation may cause irritation to the nose, throat, upper respiratory tract and lungs. No deaths occurred
11.3	Dermal	LD50: > 20000 mg/kg (rabbit) Prolonged skin contact is unlikely to result in absorption of harmful amounts. Skin irritation by prolonged exposure is unlikely. Repeated contact may cause flaking and softening of skin
11.4	Eyes	Slight irritation is possible. Direct contact with eyes may cause temporary irritation. Corneal injury is unlikely.
11.5	Sensitisation	Patch test on human volunteers did not demonstrate sensitisation properties.
11.6	CMR Carcinogenicity	Animal testing did not show any carcinogenic effects. Information given is based on data obtained from similar substances.
11.7	Mutagenicity	No data available.
11.8	Reproductive toxicity	No data available.
11.9	Specific Target Organ Toxicity	Single exposure no data available. Repeated exposure no data available.
11.10	Other toxic properties	Repeated dose toxicity. In rare cases, repeated excessive exposure to propylene glycol may cause central nervous system effects. Aspiration hazard: Due to its physical properties, the substance does probably not pose any aspiration hazard.
11.11	Other relevant toxicity information	Handle in accordance with good industrial hygiene and safety practice.
11.12	Experience with human exposure	Health injuries are not known or expected under normal use.

Document	M-007	Version	1.5	Date	19/06/25	Author	JWB	Page	38
----------	-------	---------	-----	------	----------	--------	-----	------	----

<p>Applied Thermal Control Ltd 39 Hayhill Industrial Estate Barrow upon Soar, Leicestershire LE12 8LD, United Kingdom</p>		<p>SAFETY DATA SHEET HEXID A4 HEAT TRANSFER FLUID Conforming to Directive 1907/2006/EC</p>		 SDIGROUP	
Issue	6.7	Date	April 2025	Page	5
SECTION 12: ECOLOGICAL INFORMATION					
12.1	Acute toxicity	Fish - LC50: 40613 mg/l (Oncorhynchus mykiss; 96 h) (static test) Daphnia and other aquatic invertebrates - LC50: 18340 mg/l (Ceriodaphnia Dubia (water flea); 48 h) (static test) Algae - ErC50: 19000 mg/l (Pseudokirchneriella subcapitata (green algae); 96 h) (Growth inhibition) Bacteria - NOEC: > 20000 mg/l (Pseudomonas putida; 18 h) Chronic toxicity Aquatic invertebrates - NOEC: 13020 mg/l (Ceriodaphnia Dubia (water flea); 7 d) (semi-static test)			
12.2	Persistence and degradability	Biodegradability 81 % (anaerobic; Exposure Time: 28 d)(OECD 301 F) Readily biodegradable 96 % (anaerobic; Exposure Time: 64 d)(OECD 306.)			
12.3	Bioaccumulative potential	BCF - 0.09 estimated Low bioaccumulative potential			
12.4	Mobility	Estimated Koc < 1, indicating very high soil mobility.			
12.5	PBT and vPvB assessment	Not a PBT or vPvB substance or mixture			
12.6	Other adverse affects	Do not flush into surface water or sanitary sewer system. Avoid subsoil penetration. This substance is not in Annex I of Regulation (EC) 2037/2000 on substances that deplete the ozone layer.			
SECTION 13: DISPOSAL CONSIDERATION					
13.1	Waste treatment methods	Disposal together with normal waste is not allowed. Special disposal required according to local regulations. Do not let product enter drains. Contact waste disposal services.			
13.2	Contaminated packaging	Empty contaminated packaging thoroughly. They can be recycled after thorough and proper cleaning. Packaging that cannot be cleaned are to be disposed of in the same manner as the product.			
13.3	European Waste Catalogue Number	No waste code according to the European Waste Catalogue can be assigned for this product, as the intended use dictates the assignment. The waste code is established in consultation with the regional waste disposer.			
SECTION 14: TRANSPORT INFORMATION					
Not dangerous goods for ADR, RID, IMDG, and IATA					
14.1	EEC Regulations	UNNO None. Class None. Packing Group None. Road & Rail Transport (ADR & RID) None. IMDG Not Applicable. ICOA None.			
14.2	Export commodity code	39074000 Classification - Polycarbonates			
14.3	Weight and dimensions	5Kg per 5 litre container. 19x14x29cm			
14.4	Manufactured in the United Kingdom				

Document	M-007	Version	1.5	Date	19/06/25	Author	JWB	Page	39
----------	-------	---------	-----	------	----------	--------	-----	------	----

Applied Thermal Control Ltd
39 Hayhill Industrial Estate
Barrow upon Soar, Leicestershire
LE12 8LD, United Kingdom

SAFETY DATA SHEET
HEXID A4 HEAT TRANSFER FLUID
Conforming to Directive 1907/2006/EC



Issue 6.7 Date April 2025 Page 6

SECTION 15: REGULATORY INFORMATION

15.1	Classification	Not classified as hazardous to users.
15.2	CAS No.	57556
15.3	Risk or Safety phrases	None
15.4	Labelling	None

SECTION 14: OTHER INFORMATION

Key literature references and sources for data taken from supplier information and data from the "Database of registered substances" of the European Chemicals Agency (ECHA) were used to create this safety data sheet. Other information - The information provided in this Safety Data Sheet is correct to our knowledge at the date of its revision. The information given only describes the products with regard to safety arrangements and is not to be considered as a warranty or quality specification and does not constitute a legal relationship.

The information contained in this Safety Data Sheet relates only to the specific material designated and may not be valid for such material used in combination with any other material or in any process, unless specified in the text.

Document	M-007	Version	1.5	Date	19/06/25	Author	JWB	Page	40
----------	-------	---------	-----	------	----------	--------	-----	------	----

10.3 HEXID A6 SAFETY DATA SHEET

Applied Thermal Control Ltd 39 Hayhill Industrial Estate Barrow upon Soar, Leicestershire LE12 8LD, United Kingdom		SAFETY DATA SHEET HEXID A6 HEAT TRANSFER FLUID Conforming to Directive 1907/2006/EC		 SDIGROUP	
Issue	6.7	Date	April 2025	Page	1
SECTION 1: IDENTIFICATION OF THE SUBSTANCE/MIXTURE AND OF THE COMPANY/UNDERTAKING					
1.1	Product Name	Hexid A4			
1.2	Intended/Recommended Use	Heat Transfer Fluid			
1.3	Manufacturer	Applied Thermal Control Limited 39 Hayhill Industrial Estate, Barrow upon Soar, Leicestershire, LE12 8LD, United Kingdom. www.app-therm.com			
1.4	Emergency Telephone Number	+44(0)1530 839998			
1.5	Email	sales@app-therm.com			
SECTION 2: HAZARDS IDENTIFICATION					
2.1	Classification of the substance or mixture	The product is not classified as dangerous according to Regulation (EC) No. 1272/2008. This mixture is not classified as dangerous according to Directive 1999/45/EC. This mixture has no classification under CLP			
2.2	Label elements	Label elements: This product has no label elements Signal Word: No signal word. Hazard statements: No known significant effects or critical hazards. Precautionary statements: Prevention, Response, Storage or Disposal: Not applicable.			
2.3	Other hazards	PBT: This product is not identified as a PBT/vPvB substance.			
SECTION 3: COMPOSITION/INFORMATION ON INGREDIENTS					
3.1	Chemical Nature	Water (CAS 7732-18-5), not classified. Propylene glycol (CAS 57-55-6) (REACH 01-2119456809-23) (EINECS 200-338-0) not classified. Fluorescein (trace) and biocide (trace) not classified.			
3.2	Food Grade	Food Grade			
SECTION 4: FIRST AID MEASURES					
4.1	General advice	No special precautions required. Treat symptomatically.			
4.1	Eye Contact	Rinse thoroughly with plenty of water, also under the eyelids. Remove contact lenses after a few minutes and continue rinsing. If symptoms persist, call a physician.			
4.2	Skin Contact	Wash off immediately with plenty of water. If skin irritation persists, call a physician.			
4.3	Inhalation	Remove to fresh air. If symptoms persist, call a physician.			
4.4	Ingestion	Rinse mouth with water. Never give anything by mouth to an unconscious person. If symptoms persist, call a physician.			

Document	M-007	Version	1.5	Date	19/06/25	Author	JWB	Page	41
----------	-------	---------	-----	------	----------	--------	-----	------	----

Applied Thermal Control Ltd
39 Hayhill Industrial Estate
Barrow upon Soar, Leicestershire
LE12 8LD, United Kingdom

SAFETY DATA SHEET HEXID A6 HEAT TRANSFER FLUID Conforming to Directive 1907/2006/EC



Issue	6.7	Date	April 2025	Page	2
-------	-----	------	------------	------	---

SECTION 5: FIREFIGHTING MEASURES

- | | | |
|-----|--------------------------------------|---|
| 5.1 | Extinguishing media | Use extinguishing measures that are appropriate to local circumstances and the surrounding environment.
Water spray, foam, dry powder or CO ₂ . Alcohol-resistant foam |
| 5.2 | Unsuitable extinguishing Media | High volume water jet. Do not use a solid water stream as it may scatter and spread fire. |
| 5.3 | Specific hazards during firefighting | In fire conditions, toxic decomposition products may be formed (see also section 10). In combustion, emits fumes, smoke, carbon dioxide (CO ₂) and carbon monoxide (CO). Heating will cause a pressure rise - with severe risk of bursting and explosion, Violent steam generation or eruption may occur upon application of direct water to hot liquids. |
| 5.4 | Advice for firefighters | In the event of fire, wear self-contained breathing apparatus. Wear personal protective equipment. Promptly isolate the scene by removing all persons from the vicinity of the incident if there is a fire. Keep containers cool by spraying with water if exposed to fire. Collect contaminated fire extinguishing water separately. This must not be discharged into drains. Burning fluids may be extinguished by dilution with water. |

SECTION 6: ACCIDENTAL RELEASE MEASURES



- | | | |
|-----|---------------------------------------|---|
| 6.1 | Personal precautions | Use personal protective equipment. Avoid contact with skin and eyes. Keep unnecessary and unprotected personnel from entering the area. |
| 6.2 | Precaution to protect the environment | Do not flush into surface water or sanitary sewer system. Avoid subsoil penetration. |
| 6.3 | Clean-up procedures | Contain the spillage, soak up with non-combustible absorbent material, (e.g. sand, earth, diatomaceous earth, vermiculite) and transfer to a container for disposal according to local/national regulations (see section 13). Keep in suitable, closed containers for disposal. Dike the area of spill to prevent spreading and pump liquid to salvage tank. Treat recovered material as described in section 13 Disposal considerations. |

SECTION 7: HANDLING AND STORAGE

- | | | |
|-----|-------------------------------|---|
| 7.1 | Precautions for safe handling | Keep container tightly closed. Handle in accordance with good industrial hygiene and safety practice. Spills of these organic materials on hot fibrous insulations may lead to lowering of the auto-ignition temperatures possibly resulting in spontaneous combustion. |
| 7.2 | Conditions for safe storage | Keep only in the original container. |

SECTION 8: EXPOSURE CONTROLS/PERSONAL PROTECTION

Document	M-007	Version	1.5	Date	19/06/25	Author	JWB	Page	42
----------	-------	---------	-----	------	----------	--------	-----	------	----

<p>Applied Thermal Control Ltd 39 Hayhill Industrial Estate Barrow upon Soar, Leicestershire LE12 8LD, United Kingdom</p>		<p>SAFETY DATA SHEET HEXID A6 HEAT TRANSFER FLUID Conforming to Directive 1907/2006/EC</p>		 	
Issue	6.7	Date	April 2025	Page	3
8.1 Control Parameters	<p>Component: Propane-1,2-diol CAS-No. 57-55-6 Other Occupational Exposure Limit Values EH40 WEL, Time Weighted Average (TWA): Total vapour and particulates.150 ppm, 474 mg/m³ EH40 WEL, Time Weighted Average (TWA): Particulate.10 mg/m³ ELV (IE), Time Weighted Average (TWA): Total vapour and particulates.150 ppm, 470 mg/m³ ELV (IE), Time Weighted Average (TWA): Particulate.10 mg/m³</p>				
8.2 Exposure controls/Appropriate engineering controls	<p>Local exhaust. If this product contains ingredients with exposure limits, use process enclosures, local exhaust ventilation or other engineering controls to keep worker exposure below any recommended or statutory limits.</p>				
Personal protective equipment	<p>Respiratory protection: Suitable respiratory protective device Combination filter: A-P2 Filter Type: Combined particulates and organic vapour type Hand protection: Category short time exposure - Break through time> 10 min Protective index: Class 1 When prolonged exposure is expected: Break through time> 120 min Protective index: Class 4 Observe the information of the glove manufacturers on permeability. Protective gloves should be chosen according to Workplace Safety Assessment. Gloves recommended according to EN 374 (protection against chemicals). Material: Chemical resistant gloves made of butyl rubber or nitrile rubber category III according to EN 374.</p>				
SECTION 9: PHYSICAL AND CHEMICAL PROPERTIES					
9.1 Appearance at 20°C	Fluorescent green clear liquid				
9.2 Odour	Almost odourless				
9.3 Flash Point	Boils without flashing				
9.4 Ignition Temperature	Not available				
9.5 Flammability Limit	Not available				
9.6 Oxidizing Properties	Not available				
9.7 Auto flammability	450°C				
9.8 Density at 25°C	~1.036g/cm ³				
9.9 pH (as is)	9				
9.10 Boiling point	102°C				
9.11 Solubility in water	Miscible				
9.12 Freezing point	-21°C				
9.13 Specific Heat Capacity	3.78kJ/kg °K				
9.14 Viscosity, Kinetic, at 25°C	3.51mPas				

Document	M-007	Version	1.5	Date	19/06/25	Author	JWB	Page	43
----------	-------	---------	-----	------	----------	--------	-----	------	----

<p>Applied Thermal Control Ltd 39 Hayhill Industrial Estate Barrow upon Soar, Leicestershire LE12 8LD, United Kingdom</p>		<p>SAFETY DATA SHEET HEXID A6 HEAT TRANSFER FLUID Conforming to Directive 1907/2006/EC</p>			
Issue	6.7	Date	April 2025	Page	4
SECTION 10: STABILITY AND REACTIVITY					
10.1	Reactivity	Stable under recommended storage conditions. No dangerous reaction known under conditions of normal use.			
10.2	Chemical stability	No decomposition if stored and applied as directed. Stable under recommended storage conditions. Hygroscopic.			
10.3	Hazardous reactions	Hazardous polymerisation does not occur.			
10.4	Conditions to avoid	Generation of gas from decomposition causes pressure in closed systems. Keep away from direct sunlight. Avoid high temperatures. Avoid temperatures exceeding the decomposition temperature. Avoid UV light.			
10.5	Materials to avoid	Strong acids, Strong bases, Strong oxidising agents.			
10.6	Hazardous decomposition products	Aldehydes, Alcohols, Ether, Organic acids.			
SECTION 11: TOXICOLOGICAL INFORMATION					
11.1	Toxicity Oral	LD50: > 20000 mg/kg (rat) This product can present a small hazard if large quantities are swallowed.			
11.2	Inhalation	LC50: 6.15 mg/l (rat; 4 h; vapour) At ambient temperature the exposure to vapours is minimal due to a low volatility rate. Inhalation may cause irritation to the nose, throat, upper respiratory tract and lungs. No deaths occurred			
11.3	Dermal	LD50: > 20000 mg/kg (rabbit) Prolonged skin contact is unlikely to result in absorption of harmful amounts. Skin irritation by prolonged exposure is unlikely. Repeated contact may cause flaking and softening of skin			
11.4	Eyes	Slight irritation is possible. Direct contact with eyes may cause temporary irritation. Corneal injury is unlikely.			
11.5	Sensitisation	Patch test on human volunteers did not demonstrate sensitisation properties.			
11.6	CMR Carcinogenicity	Animal testing did not show any carcinogenic effects. Information given is based on data obtained from similar substances.			
11.7	Mutagenicity	No data available.			
11.8	Reproductive toxicity	No data available.			
11.9	Specific Target Organ Toxicity	Single exposure no data available. Repeated exposure no data available.			
11.10	Other toxic properties	Repeated dose toxicity. In rare cases, repeated excessive exposure to propylene glycol may cause central nervous system effects. Aspiration hazard: Due to its physical properties, the substance does probably not pose any aspiration hazard.			
11.11	Other relevant toxicity information	Handle in accordance with good industrial hygiene and safety practice.			
11.12	Experience with human exposure	Health injuries are not known or expected under normal use.			

Document	M-007	Version	1.5	Date	19/06/25	Author	JWB	Page	44
----------	-------	---------	-----	------	----------	--------	-----	------	----

Applied Thermal Control Ltd
39 Hayhill Industrial Estate
Barrow upon Soar, Leicestershire
LE12 8LD, United Kingdom

SAFETY DATA SHEET HEXID A6 HEAT TRANSFER FLUID

Conforming to Directive 1907/2006/EC



Issue	6.7	Date	April 2025	Page	5
-------	-----	------	------------	------	---

SECTION 12: ECOLOGICAL INFORMATION

12.1	Acute toxicity	Fish - LC50: 40613 mg/l (Oncorhynchus mykiss; 96 h) (static test) Daphnia and other aquatic invertebrates - LC50: 18340 mg/l (Ceriodaphnia Dubia (water flea); 48 h) (static test) Algae - ErC50: 19000 mg/l (Pseudokirchneriella subcapitata (green algae); 96 h) (Growth inhibition) Bacteria - NOEC: > 20000 mg/l (Pseudomonas putida; 18 h) Chronic toxicity Aquatic invertebrates - NOEC: 13020 mg/l (Ceriodaphnia Dubia (water flea); 7 d) (semi-static test)
12.2	Persistence and degradability	Biodegradability 81 % (anaerobic; Exposure Time: 28 d)(OECD 301 F) Readily biodegradable 96 % (anaerobic; Exposure Time: 64 d)(OECD 306.)
12.3	Bioaccumulative potential	BCF - 0.09 estimated Low bioaccumulative potential
12.4	Mobility	Estimated Koc < 1, indicating very high soil mobility.
12.5	PBT and vPvB assessment	Not a PBT or vPvB substance or mixture
12.6	Other adverse affects	Do not flush into surface water or sanitary sewer system. Avoid subsoil penetration. This substance is not in Annex I of Regulation (EC) 2037/2000 on substances that deplete the ozone layer.



SECTION 13: DISPOSAL CONSIDERATION

13.1	Waste treatment methods	Disposal together with normal waste is not allowed. Special disposal required according to local regulations. Do not let product enter drains. Contact waste disposal services.
13.2	Contaminated packaging	Empty contaminated packaging thoroughly. They can be recycled after thorough and proper cleaning. Packaging that cannot be cleaned are to be disposed of in the same manner as the product.
13.3	European Waste Catalogue Number	No waste code according to the European Waste Catalogue can be assigned for this product, as the intended use dictates the assignment. The waste code is established in consultation with the regional waste disposer.

SECTION 14: TRANSPORT INFORMATION

Not dangerous goods for ADR, RID, IMDG, and IATA		
14.1	EEC Regulations	UNNO None. Class None. Packing Group None. Road & Rail Transport (ADR & RID) None. IMDG Not Applicable. ICOA None.
14.2	Export commodity code	39074000 Classification - Polycarbonates
14.3	Weight and dimensions	5Kg per 5 litre container. 19x14x29cm
14.4	Manufactured in the United Kingdom	

Document	M-007	Version	1.5	Date	19/06/25	Author	JWB	Page	45
----------	-------	---------	-----	------	----------	--------	-----	------	----

Applied Thermal Control Ltd 39 Hayhill Industrial Estate Barrow upon Soar, Leicestershire LE12 8LD, United Kingdom	SAFETY DATA SHEET HEXID A6 HEAT TRANSFER FLUID Conforming to Directive 1907/2006/EC	 			
Issue	6.7	Date	April 2025	Page	6
<hr/> SECTION 15: REGULATORY INFORMATION <hr/>					
15.1 Classification	<u>Not classified as hazardous to users.</u>				
15.2 CAS No.	<u>57556</u>				
15.3 Risk or Safety phrases	<u>None</u>				
15.4 Labelling	<u>None</u>				
<hr/> SECTION 14: OTHER INFORMATION <hr/>					
<p>Key literature references and sources for data taken from supplier information and data from the "Database of registered substances" of the European Chemicals Agency (ECHA) were used to create this safety data sheet.</p> <p>Other information - The information provided in this Safety Data Sheet is correct to our knowledge at the date of its revision. The information given only describes the products with regard to safety arrangements and is not to be considered as a warranty or quality specification and does not constitute a legal relationship.</p> <p>The information contained in this Safety Data Sheet relates only to the specific material designated and may not be valid for such material used in combination with any other material or in any process, unless specified in the text.</p>					

Document	M-007	Version	1.5	Date	19/06/25	Author	JWB	Page	46
----------	-------	---------	-----	------	----------	--------	-----	------	----

10.4 COOLFLOW EG SAFETY DATA SHEET



Safety Data Sheet

Applied Thermal Control Ltd
39 Hayhill Industrial Estate
Barrow Upon Soar
Leicestershire, LE12 8LD

Tel: +44(0) 1530 839998

Temperature Control for Industrial, Medical & Scientific Applications

sales@app-therm.com
www.app-therm.com

Section 1: Identification of the substance/ mixture and of the company/ undertaking

1.1 Product identifier

Product Name CoolFlow EG

1.2 Relevant identified uses of the substance or mixture and uses advised against

Identified uses Industrial grade secondary refrigerant with antifreeze and inhibitor functions designed for use in process cooling, refrigeration and HVAC systems.

Uses advised against This product is not recommended for any industrial, professional or consumer use other than the identified uses above.

1.3 Details of the supplier of the Safety Data Sheet

Supplier Applied Thermal Control Ltd
39 Hayhill Industrial Estate
Barrow Upon Soar
Leicestershire
LE12 8LD
+44 (0) 01530 839998
sales@app-therm.com

1.4 Opening Hours Monday-Thursday - 08:00 - 17:00 Friday - 08:00 - 14:00

Section 2: Hazards identification

2.1 Classification of the substance or mixture

Classification - Regulation (EC) No. 1272/2008 (CLP)

Physical and chemical hazards Not classified as a physical or chemical hazard
Human health Acute Tox. 4 - H302, STOT RE 2 - H373
Environment Not classified as an environmental hazard

2.2 Label elements

EC No. N/A

Labelling - Regulation (EC) No. 1272/2008 (CLP)

Pictograms



Signal Word - Warning

SD-015-2

CoolFlow EG Antifreeze

User & Operation Manual

MG-SERIES CHILLERS

Document	M-007	Version	1.5	Date	19/06/25	Author	JWB	Page	47
----------	-------	---------	-----	------	----------	--------	-----	------	----



Safety Data Sheet

Applied Thermal Control Ltd
39 Hayhill Industrial Estate
Barrow Upon Soar
Leicestershire, LE12 8LD

Tel: +44(0) 1530 839998

Temperature Control for Industrial, Medical & Scientific Applications

sales@app-therm.com
www.app-therm.com

Hazard statements

H302 - Harmful if swallowed

H373 - May cause damage to organs - Kidneys - through prolonged or repeated exposure if swallowed.

Precautionary statements

P260 - Do not breathe dust/fumes/gas/mist/vapours/spray

P264 - Wash hands thoroughly after handling

P270 - Do not eat, drink or smoke when using this product

P301+P312 - IF SWALLOWED: Call a POISON CENTRE or doctor/physician if you feel unwell

P301+P330+P331 - IF SWALLOWED: Rinse mouth. Do NOT induce vomiting.

2.3 Other hazards

This product does not meet the PBT/vPvB criteria of REACH, annex XIII.

Section 3: Composition/information on ingredients

3.2 Mixtures

Component - Monoethylene glycol (ethane-1, 2-diol)

Concentration 80-95%
EC No. 203-473-3
CAS No. 107-21-1
Reach registration No. 01-2119456816-28

Classification - Regulation (EC) No. 1272/2008 (CLP)

Acute Tox. 4 - H302
STOT RE 2 - H373

Component - Ethanol

Concentration 1-5%
EC No. 200-578-6
CAS No. 64-17-5
Reach registration No. 01-211945719-43

Classification - Regulation (EC) No. 1272/2008 (CLP)

Flam. Liq. 2 - H225
Eye Irrit. 2 - H319

Component - Sodium nitrite

Concentration <0.25%
EC No. 231-555-9
CAS No. 7632-00-0
Reach registration No. 01-2119471836-27

Classification - Regulation (EC) No. 1272/2008 (CLP)

Ox. Sol. 3 - H272
Acute Tox. 3 - H301
Eye Irrit. 2 - H319
Aquatic Acute 1 - H400

SD-015-2

CoolFlow EG Antifreeze



User & Operation Manual

MG-SERIES CHILLERS

Document	M-007	Version	1.5	Date	19/06/25	Author	JWB	Page	48
----------	-------	---------	-----	------	----------	--------	-----	------	----



Safety Data Sheet

Applied Thermal Control Ltd
39 Hayhill Industrial Estate
Barrow Upon Soar
Leicestershire, LE12 8LD

Tel: +44(0) 1530 839998

Temperature Control for Industrial, Medical & Scientific Applications

sales@app-therm.com
www.app-therm.com

Section 4: First aid procedures

4.1 Description of first aid procedures

General Information	When safe to do so remove the victim from the source of exposure giving consideration as to whether this may cause further discomfort to the victim.
Inhalation	Move the affected person to fresh air at once. Keep warm in a position comfortable for breathing. If breathing becomes difficult, properly trained personnel may assist the victim by supplying oxygen to ease breathing. Get medical attention if any discomfort continues.
Ingestion	Do NOT induce vomiting and seek medical attention immediately. Move victim to fresh air and keep warm and at rest in a position comfortable for breathing. Give victim approximately 250 mL of water however, do not give victim anything to drink if not fully conscious. If medical advice is delayed and an adult has consumed several ounces of this chemical, give approximately 100 mL of hard liquor (for children give 2 mL per kilogram of body weight).
Skin Contact	Remove contaminated clothing immediately and wash skin with soap and water. Get medical attention if any discomfort continues.
Eye Contact	Rinse immediately with plenty of water. Remove any contact lenses and open eyelids wide apart. Continue to rinse for at least 15 minutes. Get medical attention if any discomfort continues.

4.2 Most important symptoms and effects, both acute and delayed

General Information	The following symptoms are listed in case of exposure to the 100% neat product.
Inhalation	Inhalation of vapours may cause mild irritation of the upper respiratory tract.
Ingestion	Initial symptoms may include an upset stomach, nausea, vomiting and diarrhoea. Symptoms may progress to hyperventilation, metabolic acidosis, cardiovascular dysfunction and acute kidney failure depending on the extent of poisoning.
Skin Contact	Prolonged and repeated contact may cause mild irritation of the skin.
Eye Contact	Direct eye contact may cause reddening of the eyes.

4.3 Indication of immediate medical needs or special treatment

If several ounces (> 50 mL) of this product have been ingested, early administration of ethanol may help to counteract the toxic side effects such as metabolic acidosis, cardiovascular dysfunction and in severe cases kidney failure. Consider haemodialysis or peritoneal dialysis and thiamine 100 mg plus pyridoxine 50 mg intravenously every 6 hours. If ethanol is used a therapeutically effective blood concentration in the range of 100-150 mg/dL may be achieved by a rapid loading dose followed by a continuous intravenous fusion.

Respiratory symptoms such as pulmonary edema, may be delayed. Victims receiving significant exposure should be kept under observation for 24-48 hours for signs of respiratory distress. In the case of severe poisoning, respiratory support with mechanical ventilation and oxygenation of the patient.

Notes for the doctor

No specific recommendations in addition to the suggestions in Sections 4.1 and 4.3. Treat symptomatically.

SD-015-2

CoolFlow EG Antifreeze



User & Operation Manual

MG-SERIES CHILLERS

Document	M-007	Version	1.5	Date	19/06/25	Author	JWB	Page	49
----------	-------	---------	-----	------	----------	--------	-----	------	----



Safety Data Sheet

Applied Thermal Control Ltd
39 Hayhill Industrial Estate
Barrow Upon Soar
Leicestershire, LE12 8LD

Tel: +44(0) 1530 839998

Temperature Control for Industrial, Medical & Scientific Applications

sales@app-therm.com
www.app-therm.com

Section 5: Firefighting measures

5.1 Extinguishing media

Extinguish with alcohol-resistant foam, carbon dioxide (CO₂), dry chemicals, sand and dolomite or water fog.

5.2 Special hazards arising from the substance or mixture

Specific Hazards When heated and in the case of a fire, harmful vapours/gases (such as carbon monoxide and carbon dioxide) may be formed.

Unusual fire and explosion hazards Exposure to extreme heat may cause product containers to explode.

5.3 Advice for firefighting

Protective actions during firefighting Move containers away from fire area if this can be done without risk. Keep people away, isolate the fire and deny unnecessary entry. Use water fog to keep fire-exposed containers cool and disperse vapours. Runoff water should be prevented from entering sewers and watercourses.

Specialist protective equipment for Wear positive-pressure self-contained breathing apparatus (SCBA) and full Fire fighters protective clothing.

Section 6: Procedure for unwanted emissions

6.1 Personal precautions, protective equipment and emergency procedures

Personal precautions

Avoid flames, sparks, heat and smoking.
In the case of inadequate ventilation, use respiratory protection.

Protective Equipment

Wear protective clothing as described in Section 8 of this Safety Data Sheet.

Emergency Procedures

Stop leak/release if possible to do so without risk.
Extinguish all ignition sources if safe to do so.
Warn everybody of potential danger and evacuate if necessary.

6.2 Environmental precautions

Do not discharge into drains, water courses or onto the ground.
Spillages or uncontrolled discharges into watercourses must be reported immediately to the Environmental Agency or other appropriate regulatory body.

6.3 Methods and materials for containment and clean up

Absorb spillage with inert, damp, non-combustible material, then flush the contaminated area with water.
Containers with collected spillage should be appropriately labelled with the correct contents and hazard labels.
Collect and place in suitable waste disposal containers and seal securely. For waste disposal, see Section 13.

6.4 Reference to other sections

Wear protective clothing as described in Section 8 of this Safety Data Sheet.
Collect and dispose of spillage as indicated in Section 13.

SD-015-2

CoolFlow EG Antifreeze



Document	M-007	Version	1.5	Date	19/06/25	Author	JWB	Page	50
----------	-------	---------	-----	------	----------	--------	-----	------	----



Safety Data Sheet

Applied Thermal Control Ltd
39 Hayhill Industrial Estate
Barrow Upon Soar
Leicestershire, LE12 8LD

Tel: +44(0) 1530 839998

Temperature Control for Industrial, Medical & Scientific Applications

sales@app-therm.com
www.app-therm.com

Section 7: Handling and storage

7.1 Precautions for safe handling

Avoid spilling and contact with the skin and the eyes as well as direct inhalation of sprays and mists.
Provide good ventilation.
Do not eat, drink or smoke in work areas and wash hands after handling this product.

7.2 Conditions for safe storage including any compatibilities

Store in tightly-closed, original containers.
Keep separate from food, feedstuffs, fertilisers and other sensitive material.
Do not store near heat sources or expose to high temperatures.
Keep away from heat, sparks and open flame.

7.3 Specific end use(es)

The identified uses for this product are detailed in Section 1.2.

Section 8: Exposure controls / Personal protection

8.1 Control parameters

Name	STD	TWA-8 Hrs	STEL-15 Min
Monoethylene glycol (ethane-1, 2-diol)	WEL	52 mg/m ³	104 mg/m ³

DNEL

Industry, Inhalation - Long term local effects: 35mg/m³
Industry, Dermal - Long term systemic effects: 106mg/m³
Consumer, Inhalation - Long term local effects: 7mg/m³
Consumer, Dermal - Long term systemic effects: 7mg/m³

PNEC

Fresh water: 10 mg/L
Marine water: 1mg/L
STP: 199.5 mg/L
Sediment fresh water: 20.9 mg/kg
Soil: 1.53 mg/kg

Name	STD	TWA-8 Hrs	STEL-15 Min
Ethanol	WEL	1920 mg/m ³	Not available

DNEL

Industry, Inhalation - Short term local effects: 1900 mg/m³
Industry, Dermal - Long term systemic effects: 343 mg/kg/day
Industry, Inhalation - Long term systemic effects: 950 mg/m³
Consumer, Inhalation - Short term local effects: 950 mg/m³

Consumer, Dermal - Long term systemic effects: 206 mg/kg/day
Consumer, Inhalation - Long term systemic effects: 114 mg/m³
Consumer, Oral - Long term systemic effects: 87 mg/kg/day

PNEC

Fresh water: 0.96 mg/L
Marine water: 0.79 mg/L

SD-015-2

CoolFlow EG Antifreeze

User & Operation Manual

MG-SERIES CHILLERS

Document	M-007	Version	1.5	Date	19/06/25	Author	JWB	Page	51
----------	-------	---------	-----	------	----------	--------	-----	------	----



Safety Data Sheet

Applied Thermal Control Ltd
39 Hayhill Industrial Estate
Barrow Upon Soar
Leicestershire, LE12 8LD

Tel: +44(0) 1530 839998

Temperature Control for Industrial, Medical & Scientific Applications

sales@app-therm.com
www.app-therm.com

Intermittent release: 2.75 mg/L
STP: 580 mg/L
Sediment fresh water: 3.6 mg/kg
Sediment marine water: 2.9 mg/kg
Soil: 0.63 mg/kg

Name	STD	TWA-8 Hrs	STEL-15 Min
Sodium nitrite	WEL	Not available	Not available

DNEL

Industry, Inhalation - Long term systemic effects: 2 mg/m³
Industry, Inhalation - Short term systemic effects: 2 mg/m³

PNEC

Fresh water: 0.0054 mg/L
Marine water: 0.00616 mg/L
Intermittent release: 0.0054 mg/L
Sediment (fresh water): 0.0195 mg/kg
Sediment (marine water): 0.0223 mg/kg
STP: 21 mg/L

8.2 Exposure controls



Technical procedures

Engineering measures

Methods to prevent or control exposure are preferred. Provide adequate ventilation to minimise the risk of inhalation of sprays and mists.

Hygiene measures

Handle in accordance with good industrial hygiene and safety practices. Wash hands after handling this product and at the end of each work shift. Routinely wash work clothing and personal protective equipment to remove possible contaminants.

Respiratory equipment

Where risk assessment shows air-purifying respirators are appropriate use a full-face respirator with multi-purpose combination (US) or type ABEK (EN 14387) respirator cartridges as a backup to engineering controls. If the respirator is the sole means of protection, use a full-face supplied air respirator. Use respirators and components tested and approved under appropriate government standards such as NIOSH (US) or CEN (EU).

Hand protection

PVC/butyl rubber/neoprene gloves are recommended.

Eye protection Skin Protection Other Protection

Wear approved chemical goggles or face shield.
Wear rubber apron or protective clothing in case of contact.
Wear suitable protective clothing/footwear as protection against splashing or contamination.

SD-015-2

CoolFlow EG Antifreeze



User & Operation Manual

MG-SERIES CHILLERS

Document	M-007	Version	1.5	Date	19/06/25	Author	JWB	Page	52
----------	-------	---------	-----	------	----------	--------	-----	------	----



Safety Data Sheet

Applied Thermal Control Ltd
39 Hayhill Industrial Estate
Barrow Upon Soar
Leicestershire, LE12 8LD

Tel: +44(0) 1530 839998

Temperature Control for Industrial, Medical & Scientific Applications

sales@app-therm.com
www.app-therm.com

Thermal Hazards	No specific measures required.
Environmental Exposure Controls	Product not classified as an environmental hazard - no specific environmental exposure controls required.

Section 9: Physical and chemical properties

9.1 Information on basic physical and chemical properties

Appearance	Blue liquid
Odour	Non-pungent but characteristic aroma
Odour Threshold	Not applicable
pH	7.5 - 10.5 depending on inhibitor formulation
Melting point / Pour point	-40°C
Initial boiling point	>180°C
Flash point	>64°C
Evaporation Rate	No test data available
Flammability	Product is not classified as flammable
Flammability / explosion limits	Upper limit: 13% Lower limit: 3%
Vapour pressure	No test data available
Vapour density (air = 1)	No test data available
Relative density of the mixture	1.04 - 1.2
Solubility	Soluble in water
Partition coefficient: n-octanol / water	No test data available
Auto-ignition temperature	>390°C
Decomposition temperature	No test data available
Viscosity	See product data sheet
Explosive properties	Not applicable - product is not classified as an explosive
Oxidising properties	Not applicable - product is not classified as an oxidising agent

9.2 Other information

Not determined.

Section 10: Stability and reactivity

10.1 Reactivity

There are no known reactivity hazards associated with this product.

10.2 Chemical stability

Stable at normal ambient temperatures and when used as recommended.
Product is hygroscopic and will absorb water by contact with the moisture in the air.

10.3 Possibility of hazardous reactions

There are no known hazardous reactions associated with this product.

10.4 Conditions to avoid

Avoid temperatures >180°C for prolonged periods of time, flames and sources of ignition.

10.5 Incompatible materials

Strong acids, strong alkalis and strong oxidising agents.

10.6 Hazardous decomposition products

SD-015-2

CoolFlow EG Antifreeze



User & Operation Manual

MG-SERIES CHILLERS

Document	M-007	Version	1.5	Date	19/06/25	Author	JWB	Page	53
----------	-------	---------	-----	------	----------	--------	-----	------	----



Safety Data Sheet

Applied Thermal Control Ltd
39 Hayhill Industrial Estate
Barrow Upon Soar
Leicestershire, LE12 8LD

Tel: +44(0) 1530 839998

Temperature Control for Industrial, Medical & Scientific Applications

sales@app-therm.com
www.app-therm.com

No known hazardous decomposition products. Potentially hazardous products released due to fire are listed in Section 5.2 of this Safety Data Sheet.

Section 11: Toxicological information

11.1 Information on toxicological effects

Acute toxicity

This product has not been tested as a whole for acute toxicity health effects. For this reason, the acute toxicity values for the main components of this mixture are listed below.

Acute toxicity values for monoethylene glycol:

LD50, oral, rat: 4700 mg/kg bw

LD50, dermal, rabbit: >10,600 mg/kg bw

LD50, dermal, mouse: >3500 mg/kg bw

LC50, inhalation (vapours), rat: >2.5 mg/L

Oral toxicity of monoethylene glycol is expected to be moderate in humans despite animal testing showing a lower degree of toxicity. The estimated lethal dose in humans of NEAT MONOETHYLENE GLYCOL is expected to be approximately 100mL.

Acute toxicity values for ethanol:

LD50, oral, rat: 10,470 mg/kg bw

LD50, dermal rabbit: 17,100 mg/kg bw

Skin corrosion/ irritation
Serious eye damage/ irritation

Skin irritation is not expected when this product is used/handled correctly.
Eye irritation is not expected when this product is used/handled correctly.

Respiratory/ skin sensitisation
Germ cell mutagenicity
Carcinogenicity
Reproductive toxicity

Product not classified as a skin/respiratory sensitiser.
Product is not expected to be mutagenic.
Product is not expected to be carcinogenic.
Product is not expected to damage the reproductive system or harm a developing fetus.

Evaluation of CMR properties
STOT-single exposure

No test data available.
No test data available.

STOT-repeated exposure
Aspiration hazard

No test data available.
No test data available.

General information

See Section 4.2 of this Safety Data Sheet.

Inhalation

Inhalation of vapours may cause mild irritation of the upper respiratory tract.

Ingestion

Initial symptoms may include an upset stomach, nausea, vomiting and diarrhoea. Symptoms may progress to hyperventilation, metabolic acidosis, cardiovascular dysfunction and acute kidney failure depending on the extent of poisoning.

Skin contact

Prolonged and repeated contact may cause mild irritation of the skin.

Eye contact

Direct eye contact may cause reddening of the eyes.

SD-015-2

CoolFlow EG Antifreeze



User & Operation Manual

MG-SERIES CHILLERS

Document	M-007	Version	1.5	Date	19/06/25	Author	JWB	Page	54
----------	-------	---------	-----	------	----------	--------	-----	------	----



Safety Data Sheet

Applied Thermal Control Ltd
39 Hayhill Industrial Estate
Barrow Upon Soar
Leicestershire, LE12 8LD

Tel: +44(0) 1530 839998

Temperature Control for Industrial, Medical & Scientific Applications

sales@app-therm.com
www.app-therm.com

Section 12: Ecological information

Ecotoxicity

The product is not classified as hazardous to the environment.

12.1 Toxicity

LC50, 96 hours, fish: >100 mg/L - not classified as harmful to fish
EC50, 48 hours, daphnia magna: >100 mg/L - not classified as harmful to daphnia
EC50, 96 hours, aquatic plants: >100 mg/L - not classified as harmful to aquatic plants

12.2 Persistence and degradability

This product is readily biodegradable (90% over 10 days).

12.3 Bioaccumulative potential

Will not bio-accumulate.
Partition coefficient - not determined.

12.4 Mobility in soil

Product is mobile in soil as it is water soluble.

12.5 Results of PBT and vPvB assessment

This product does not meet the PBT/vPvB criteria of REACH, annex XIII.

12.6 Other adverse effects

Not determined.

Section 13: Advice on disposal

General information

Waste to be treated as controlled waste. Disposal to licensed waste disposal site in accordance with Local Waste Disposal Authority.

Disposal methods

Dispose of waste and residues in accordance with local authority and/or local sewage treatment plant requirements.

Section 14: Transport information

14.1 UN number

Product not hazardous for transport - no information required.

14.2 UN proper shipping name

Product not hazardous for transport - no information required

14.3 Transport hazard class(es)

Product not hazardous for transport - no information required.

Transport labels

Product not hazardous for transport - no information required.

14.4 Packing group

Product not hazardous for transport - no information required.

SD-015-2

CoolFlow EG Antifreeze



User & Operation Manual

MG-SERIES CHILLERS

Document	M-007	Version	1.5	Date	19/06/25	Author	JWB	Page	55
----------	-------	---------	-----	------	----------	--------	-----	------	----



Safety Data Sheet

Applied Thermal Control Ltd
39 Hayhill Industrial Estate
Barrow Upon Soar
Leicestershire, LE12 8LD

Tel: +44(0) 1530 839998

Temperature Control for Industrial, Medical & Scientific Applications

sales@app-therm.com
www.app-therm.com

14.5 Environmental hazards

Product not classed as an environmentally hazardous substance or marine pollutant.

14.6 Special precautions for user

Product not hazardous for transport - no information required.

14.7 Transport in bulk according to Annex II of MARPOL73/78 and the IBC Code

Product not hazardous for transport - no information required.

Section 15: Regulatory information

15.1 Safety, health and environmental regulations / legislation for the substance or mixture

EU legislation

Regulation (EC) No 1907/2006 of the European Parliament and of the Council of 18 December 2006 concerning the Registration, Evaluation Authorisation and Restriction of Chemicals (REACH) (as amended). Regulation (EC) No 1272/2008 of the European Parliament and of the Council of 16 December 2008 on classification, labelling and packaging of substances and mixtures (as amended).

Guidance notes

CHIP for everyone HSG228. Approved Classification and Labelling Guide (Sixth edition) L131. Safety Data Sheets for substances and preparations.

15.2 Chemical safety assessment

No chemical safety assessment for this mixture has been carried out.

Section 16: Other information

Issued by Thermal Exchange Ltd
Revision Date 21/03/2018
Approved by Graham Wade
Revision Comments Review in line with CLP regulation

Hazard statements in full

The following hazard statements are the hazard statements 'in full' for the components of this mixture. They are not the hazard statements associated with the final classification of this product.

H302 - Harmful if swallowed
H373 - May cause damage to organs - Kidneys - through prolonged or repeated exposure if swallowed
H225 - Highly flammable liquid and vapour
H319 - Causes serious eye irritation
H272 - May intensify fire; oxidiser

H301 - Toxic if swallowed
H400 - Very toxic to aquatic life

Further classification and composition comments

No further classification or composition comments required.

SD-015-2

CoolFlow EG Antifreezeze



User & Operation Manual

MG-SERIES CHILLERS

Document	M-007	Version	1.5	Date	19/06/25	Author	JWB	Page	56
----------	-------	---------	-----	------	----------	--------	-----	------	----



Safety Data Sheet

Applied Thermal Control Ltd
39 Hayhill Industrial Estate
Barrow Upon Soar
Leicestershire, LE12 8LD
Tel: +44(0) 1530 839998

Temperature Control for Industrial, Medical & Scientific Applications

sales@app-therm.com
www.app-therm.com

(i) Indication of changes

Safety Data Sheet updated to comply with the new requirements as set out in Regulation (EC) No. 1272/2008 (CLP).

(ii) Abbreviations and acronyms

bw: bodyweight
CAS No: Chemical Abstracts Service number
CLP: Classification Labelling and Packaging Regulation
DNEL: Derived No-Effect Level
EC: European Commission
EC No: European Chemical number: EINECS, ELINCS or NLP
ECHA: European Chemicals Agency
EINECS: European Inventory of Existing Commercial Chemical Substances
ELINCS: European List of Notified Chemical Substances
LC50: Lethal Concentration, 50%
LD50: Median Lethal Dose

PBT: Persistent, Bioaccumulative & Toxic
PNEC: Predicted No Effect Concentration
REACH: Registration, Evaluation, Authorisation & restrictions of Chemicals
SDS: Safety Data Sheet
vPvB: Very Persistent and Very Bioaccumulative
WEL: Workplace Exposure Limit

(iii) Training advice

Product should only be handled by trained operators.

(iv) Additional information

The above information describes exclusively the safety requirements of the product and is based on our present-day knowledge. The information is intended to give advice about the safe handling of the product named in this Safety Data Sheet, for storage, processing, transport and disposal. The information cannot be transferred to other products. In the case of mixing the product with products or in the case of processing, the information on this Safety Data Sheet is not necessarily valid for the new made-up material.

SD-015-2

CoolFlow EG Antifreeze

