

User & Operation Manual

H-SERIES CHILLERS

| | | | | | | | | | |
|----------|-------|---------|-----|------|----------|--------|-----|------|---|
| Document | M-005 | Version | 1.1 | Date | 19/06/25 | Author | JWB | Page | 1 |
|----------|-------|---------|-----|------|----------|--------|-----|------|---|



User & Operation Manual

H-SERIES CHILLERS

| | | | | | | | | | |
|-----------------|-------|----------------|-----|-------------|----------|---------------|-----|-------------|---|
| Document | M-005 | Version | 1.1 | Date | 19/06/25 | Author | JWB | Page | 2 |
|-----------------|-------|----------------|-----|-------------|----------|---------------|-----|-------------|---|

CONTENTS

| | |
|---|----|
| 1.0 INTRODUCTION | 4 |
| 2.0 IMPORTANT INFORMATION | 5 |
| 2.1 INTENDED USE | 5 |
| 2.2 SAFETY NOTICES | 6 |
| 2.3 WASTE DISPOSAL | 9 |
| 2.4 MODEL NUMBERING | 10 |
| 2.5 UNPACKING UNITS | 11 |
| 2.6 SITE REQUIREMENTS | 11 |
| 2.7 WARRANTY REGISTRATION | 13 |
| 3.0 PRODUCT SPECIFICATIONS | 14 |
| 3.1 H03/H05 (ALL STANDARD VARIANTS) | 14 |
| 3.2 H06/H12 (ALL STANDARD VARIANTS) | 15 |
| 4.0 QUICK START GUIDE | 16 |
| 5.0 INSTALLATION..... | 17 |
| 5.1 HOSE RECOMMENDATIONS | 17 |
| 5.2 FLUID FITTINGS | 17 |
| 5.3 BACKFILLING..... | 18 |
| 5.4 VOLTAGE SELECTION | 18 |
| 5.5 FILLING PROCEDURE | 18 |
| 5.6 DRAINING A SYSTEM..... | 19 |
| 6.0 CONTROLLER OPERATION | 20 |
| 6.1 KR1 CONTROLLER | 20 |
| 6.2.1 CHANGING SETPOINT | 21 |
| 6.3 REGULATING PRESSURE/FLOW (P5 to P17) | 22 |
| 6.4 REGULATING PRESSURE/FLOW (P25-P80)..... | 24 |
| 7.0 BASIC TROUBLESHOOTING..... | 26 |
| 8.0 END USER MAINTENANCE..... | 28 |
| 9.0 DECLARATION OF CONFORMITY | 29 |
| 10.0 REFRIGERANT & HEAT TRANSFER FLUID SAFETY DATA SHEETS | 30 |

User & Operation Manual

H-SERIES CHILLERS

| | | | | | | | | | |
|-----------------|-------|----------------|-----|-------------|----------|---------------|-----|-------------|---|
| Document | M-005 | Version | 1.1 | Date | 19/06/25 | Author | JWB | Page | 3 |
|-----------------|-------|----------------|-----|-------------|----------|---------------|-----|-------------|---|

| | |
|---|----|
| 10.1 R454C SAFETY DATA SHEET | 31 |
| 10.2 HEXID A4 SAFETY DATA SHEET | 39 |
| 10.3 HEXID A6 SAFETY DATA SHEET | 45 |
| 10.4 COOLFLOW EG SAFETY DATA SHEET..... | 51 |



User & Operation Manual

H-SERIES CHILLERS

| | | | | | | | | | |
|-----------------|-------|----------------|-----|-------------|----------|---------------|-----|-------------|---|
| Document | M-005 | Version | 1.1 | Date | 19/06/25 | Author | JWB | Page | 4 |
|-----------------|-------|----------------|-----|-------------|----------|---------------|-----|-------------|---|

1.0 INTRODUCTION

By selecting an ATC product, you have invested in many years of experience in the design and manufacture of precision temperature control instrumentation.

ATC has built your unit without compromise to meet the objectives of performance and reliability. Please read this manual carefully to ensure you understand the operation of the machine and how to use the unit safely and efficiently.

CAUTION



Please read this User & Operation Manual in full. For maintenance tasks beyond that of routine cleaning, please consult the separate Maintenance Manual. This contains further information and schematics for the use of suitably qualified personnel.

Contact information

If you have any questions regarding installation or repair of this unit, please contact ATC direct.

Applied Thermal Control Ltd.

39 Hayhill Industrial Estate, Barrow Upon Soar

Leicestershire,

LE12 8LD

United Kingdom

Tel: +44 (0) 1530 839998

E-mail: support@app-therm.com



| | | | | | | | | | |
|-----------------|-------|----------------|-----|-------------|----------|---------------|-----|-------------|---|
| Document | M-005 | Version | 1.1 | Date | 19/06/25 | Author | JWB | Page | 5 |
|-----------------|-------|----------------|-----|-------------|----------|---------------|-----|-------------|---|

2.0 IMPORTANT INFORMATION

2.1 INTENDED USE

Applied Thermal Control products have been designed to control the temperature of specific fluids. The units feature inlet and outlet connections for the temperature control of external systems (process fluid circuit).

Applied Thermal Control products are not suitable for direct temperature control of foods, pharmaceutical or medical products. This is defined as unprotected contact of the object with the process fluid used by the chiller.

The product must be used in line with the instructions contained within this manual. A separate maintenance manual is also available. Particular attention should be given to the safety notices prior to installing and operating the machine.

This appliance is not intended for use by persons with reduced physical, sensory or mental capabilities, or lack of experience and knowledge, unless they have been given supervision or instruction concerning use of the appliance by a person responsible for their safety.

| | | | | | | | | | |
|----------|-------|---------|-----|------|----------|--------|-----|------|---|
| Document | M-005 | Version | 1.1 | Date | 19/06/25 | Author | JWB | Page | 6 |
|----------|-------|---------|-----|------|----------|--------|-----|------|---|



2.2 SAFETY NOTICES

R454C refrigerant is a low-GWP HFO alternative to HFC refrigerants. However, it is classified as a mildly flammable (A2L) gas. At the same temperature and pressure, R454C is heavier than air and usually reaches higher concentrations near the ground. R454c has a faint odour, but can be easily detected with commercially available gas detectors and leak detection devices.

Additional information regarding R454C refrigerant can be found in section 10.1 R454C . The refrigerant type and charge is always labelled on the unit.

For your safety, we draw your attention to the following WARNING and CAUTION marks throughout the manual. Warning symbols can be found on the unit. Ensure you have read through all warnings before starting the unit.

The safe operation of ATC products always remains the responsibility of the operator. This equipment is intended to be used as a liquid temperature conditioning device – it requires no external pump, nor any further manipulation of temperature. If the equipment is used in a manner not specified by the manufacturer, the protection provided by the equipment may be impaired. Failure to comply with a ‘WARNING’ may result in personal injury or death. ATC does not accept any liability for injury caused through misuse of this equipment.

| REFRIGERANT: R454C | |
|---|--|
| For your safety, we draw your attention to the following warning and caution marks throughout the manual Identified by the following symbols. Where relevant, these are also labelled on the machine. All warnings and cautions should be read prior to starting the machine. | |
| ⚠ WARNING | |
|  | Warnings denote a hazard that MAY cause serious personal injury or death. |
| ⚠ CAUTION | |
|  | Cautions denote a hazard that MAY cause minor personal injury or damage/failure of the product or facility. |
| <p>The safe operation of ATC products remains the responsibility of the operator at all times. This equipment is intended to be used as a liquid temperature conditioning device – it requires no external pump, nor any further manipulation of temperature.</p> <p>If the equipment is used in a manner not specified by the manufacturer, the protection provided by the equipment may be impaired. Failure to comply with a ‘warning’ may result in personal injury or death.</p> <p style="text-align: center;">ATC does not accept any liability for injury or damage caused through misuse of this equipment.</p> | |

| | | | | | | | | | |
|----------|-------|---------|-----|------|----------|--------|-----|------|---|
| Document | M-005 | Version | 1.1 | Date | 19/06/25 | Author | JWB | Page | 7 |
|----------|-------|---------|-----|------|----------|--------|-----|------|---|

WARNING



- This appliance should only be installed by persons who are appropriately trained, skilled and competent to carry out the work properly and safely. Servicing and repair is to be undertaken by qualified engineers for the handling of hydrocarbon refrigerants.
- Appliance must not be installed in public corridors or lobbies if the refrigerant charge exceeds three times the lower flammability limit (LFL). This is 880g for R454C.
- If symbol IEC 60417-6412:2019-03 is marked on the appliance, the room size in which the appliance is located must not be less than the value listed on the label.
- Do not store explosive substances such as aerosol cans with a flammable propellant within or close to this appliance.
- Do not damage the refrigerating circuit
- Do not use electrical appliances inside the enclosure of this appliance unless they are of the type recommended by the manufacturer
- To be installed in accordance with the Safety Standard for Refrigeration Systems, ANSI/ASHRAE 15 or local equivalent.
- Adequate ventilation of clean, cool and dry air is required for all air-cooled chiller appliances during normal operation and allows the chiller to operate at maximum capacity.
- If the appliance is placed in a location with floor void(s) below (such as false floors, drains or cable pathways etc.), precautions must be made to either seal the void(s) or supply adequate low-level ventilation. In particular, precautions should be made against refrigerant collecting in drains.
- If the appliance is placed in a machinery room with the increased risk of sources of ignition, it is advised that a refrigerant leak detector and a mechanical low-level ventilation system exhausting to an external atmospheric safe area is installed.
- Ensure all operatives are aware the appliance contains a flammable, odourless refrigerant.
- The ventilation system should be configured to be automatically activated upon detection of a refrigerant leak or set to continuously operate.
- Keep ventilation openings of the appliance enclosure or the structure of built in equipment clear of obstruction.

| | | | | | | | | | |
|----------|-------|---------|-----|------|----------|--------|-----|------|---|
| Document | M-005 | Version | 1.1 | Date | 19/06/25 | Author | JWB | Page | 8 |
|----------|-------|---------|-----|------|----------|--------|-----|------|---|

WARNING



- Always ensure appropriate fire extinguishers are placed at entrances and exits to the room housing the appliance(s) and adequate warning signage is installed to local laws/site requirements.
- Locate all refrigerant containing machinery so that damage from external sources would be highly unlikely.
- Should a suspected leak become apparent, immediately evacuate the area and **remotely** switch off the appliance if safe to do so.
- If a leak is suspected **DO NOT** disconnect the plug from the main supply socket or from the appliance inlet as this could act as a source of ignition. Leaking refrigerant may ignite and cause injuries.
- The appliance must be disconnected from its power source during cleaning; when maintenance and the replacement of parts is required, the equipment must be safely disconnected and isolated from the power supply using a lock-out system at the isolation device.
- It is advised that the electrical supply to the equipment is protected by an appropriately selected Residual Current Device (RCD).
- If the supply cord is damaged, it must be replaced by a service engineer or other qualified person.
- Fixed wiring appliances (those not supplied with a plug) shall incorporate a switch disconnecter to meet the specification of IEC 60947; this is to be installed within the fixed wiring installation in accordance to the local wiring rules / regulations to provide all pole disconnection of the power supply.
- Do not substitute the current refrigerant for any other refrigerant. The refrigerant used will be labelled on the appliance.
- Water pressures of up to 10 Bar during operation
- Hot and cold surfaces are present during operation.
- Always ensure the unit is isolated before service. The product is protected from overcurrent by fuses and MCBs. Never bypass these components.
- During fault diagnostics and maintenance, it may be necessary to remove panels, which expose the operator to the dangers of pressurized systems, hot or cold pipes and electrical circuits. Only qualified personnel who are aware and equipped to deal with these systems should carry out such work.
- Under no circumstances leave the product unattended with any panels/covers removed
- Any temporary electrical supply to the chiller should be correctly earthed and connected through an earth leakage trip.
- Never alter settings of pressure switches, overloads, circuit breakers or any safety device without first consulting Applied Thermal Control.

| | | | | | | | | | |
|----------|-------|---------|-----|------|----------|--------|-----|------|---|
| Document | M-005 | Version | 1.1 | Date | 19/06/25 | Author | JWB | Page | 9 |
|----------|-------|---------|-----|------|----------|--------|-----|------|---|

CAUTION



- Always wear appropriate PPE when performing routine maintenance. It is advised that suitable gloves and eye protection are used as a minimum requirement.
- Some units produce a sound level >80dBa. Site appropriately, and ensure hearing protection is worn.
- Process fluid circuits connected to the appliance are designed to safely release/bypass abnormal pressure. There will be no possibility for the release of flammable refrigerant in this scenario.
- The pressure relief valve is factory-set and there is no provision for adjustment by the end-user
- Marking and signage to the equipment must continue to be visible and legible. Marking and signs that are illegible shall be corrected.
- The appliance is to be located in a position where it is not likely to be exposed to any substance that may corrode refrigerant containing components, unless the manufacturer has explicitly supplied components are constructed of materials which are inherently resistant to being corroded, or are suitably protected against being so corroded.

2.3 WASTE DISPOSAL

This product uses R454C refrigerant and compressor oil. Follow local regulations regarding the recovery and disposal of these substances. Refrigerant recovery must be completed by personnel qualified in the handling of hydrocarbon refrigerants.

Once oil and refrigerant are removed, the product must be handled as industrial waste in accordance with local regulations.

User & Operation Manual

H-SERIES CHILLERS

| | | | | | | | | | |
|----------|-------|---------|-----|------|----------|--------|-----|------|----|
| Document | M-005 | Version | 1.1 | Date | 19/06/25 | Author | JWB | Page | 10 |
|----------|-------|---------|-----|------|----------|--------|-----|------|----|

2.4 MODEL NUMBERING



The model number of your ATC product can guide you to the sections of the manual specific to your model. The model number can be found on the serial plate of the product, similar to the below.

Applied Thermal Control Ltd
 39 Hayhill Industrial Estate
 Barrow-upon-Soar, Loughborough
 LE12 8LD, United Kingdom

+44 (0) 1530 839 998
 support@app-therm.com

Model No: G01xxxx
Refrigerant: R290 (GWP=3)
Charge: 75g (225g CO2e)
Max Pressure: 24 Bar / 348 PSI
Working Pressure: 12 Bar / 174 PSI
Process Max Flow: 10 lpm
Process Max Pressure: 8 Bar / 120 PSI
Serial No: 2xxxxxx

CE
UKCA

| VOLTS | | | | | | COMPRESSOR | | | FAN | PUMP |
|---------|----|-------|------|------|-----|------------|-----|-----|------|------|
| Ph | Hz | MCA | FUSE | BCSC | AC | RLA | LRA | MOC | FLA | FLA |
| 208-240 | 1 | 50/60 | 5A | N/A | N/A | 4.1A | N/A | 5A | 0.6A | 3A |

If the model number format shown below does not match the model number on the product serial plate, this manual will not be applicable to your product. Electronic copies of all standard product manuals are located on our website. If you have a non-standard product or require any further assistance with manuals, please contact us.

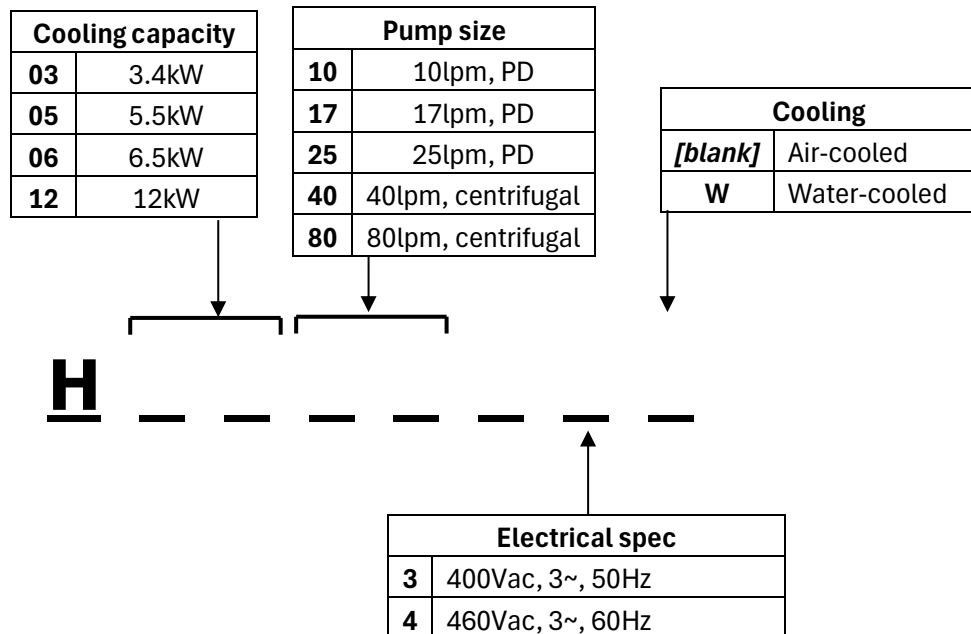

| | | | | | | | | | |
|----------|-------|---------|-----|------|----------|--------|-----|------|----|
| Document | M-005 | Version | 1.1 | Date | 19/06/25 | Author | JWB | Page | 11 |
|----------|-------|---------|-----|------|----------|--------|-----|------|----|

2.5 UNPACKING UNITS

Please check that both the packaging and the unit are undamaged. If there is any doubt, it is vital that you inform both ATC and the carrier. There are no hidden shipping bolts or other fixings. You should inspect the packaging for signs of transit damage before signing for the unit, and if possible, unpack the unit before signing. Once you have signed for the goods, ATC cannot be held responsible for any transit damage subsequently found.

ATC recommends the unit should be lifted with slings through the underside, using a forklift or overhead crane. ATC highly recommends that it is not manually lifted, and that safe slinging and lifting practices are adhered to.

Remove the unit from its original packaging and ensure that there is no packaging left around the cooling ducts. There is no internal product packaging that requires the chiller to be opened.

Please retain all packaging in the unlikely event that the chiller needs to be returned to our local representatives.

2.6 SITE REQUIREMENTS

| | |
|---|---|
| 1 | Storage temperature range. Without process fluids, -20°C to +70°C. |
| 2 | Storage humidity range. Non-condensing, relative humidity 5% to 95%. Before starting product, allow product to acclimate for 24h in location of use when storing outside <i>operating</i> humidity range. |
| 3 | Operating temperature range. With appropriate process fluids, Standard Unit: +4°C to +35°C Extended: -20°C to +90°C |
| 4 | Operating humidity range. 80% for ambient temperatures up to +31°C (+88°F), decreasing linearly to 50% relative humidity at +40°C (+104°F) ambient temperature. |
| 5 | Hard, level surface. A level surface is important for ensuring proper filling and allowing air to escape. |
| 6 | Electrical supply. Overcurrent protection: <ul style="list-style-type: none">• H03 & H05: Circuit breaker, 15A• H06 & H12: Rotary Overload, 16A For details on the required electrical supply, see production specification sections: 3.1 H03/H05 (ALL STANDARD VARIANTS) 3.2 H06/H12 (ALL STANDARD VARIANTS) |

User & Operation Manual

H-SERIES CHILLERS

| | | | | | | | | | |
|-----------------|-------|----------------|-----|-------------|----------|---------------|-----|-------------|----|
| Document | M-005 | Version | 1.1 | Date | 19/06/25 | Author | JWB | Page | 12 |
|-----------------|-------|----------------|-----|-------------|----------|---------------|-----|-------------|----|

| | |
|-----------|--|
| 8 | Clearance. Clearance is required to: a) Provide unobstructed access to the electrical panel to use MCB/isolator switch in case of emergency. b) Fit hoses and electrical supply to the rear of the unit allowing recommended bending radii. c) Allow maintenance access points and side panels to be removed. d) Allow process to take place – all models require the coolest, cleanest air that can be provided to achieve the best performance. This model draws air in from the left and right-hand sides (when viewing from the front of the unit) and rejects heated air to the rear. e) 0.5m clearance is recommended on air-on and air-off sides. Do not cover any vents. |
| 9 | Plumbing. Tubing, piping or hose must be clean and compatible with the fluid to be used. The product is compatible with deionized water and water-glycol mixtures such as Hexid A4 and A6. Ensure the connected pipework is suitable for handling the nominal flowrate at system pressure $\geq 6\text{bar}$. |
| 10 | Indoor use only. Altitude up to 2000m above sea level. Ensure the unit has adequate ventilation. |

CAUTION

| | |
|---|--|
|  | <ul style="list-style-type: none">• Always use ATC recommended fluids in our products – many sealing compounds and materials are present and unapproved fluids have the potential to corrode your application and damage seals.• Do not use inadequately rated wiring. Consult an electrician if you are unsure.• The safety of any system incorporating the equipment is the responsibility of the assembler of the system• Do not replace detachable mains cords with inadequately rated cords. Contact ATC for appropriately rated products. |
|---|--|

| | | | | | | | | | |
|----------|-------|---------|-----|------|----------|--------|-----|------|----|
| Document | M-005 | Version | 1.1 | Date | 19/06/25 | Author | JWB | Page | 13 |
|----------|-------|---------|-----|------|----------|--------|-----|------|----|

2.7 WARRANTY REGISTRATION

Please visit the website warranty registration page to ensure ATC can offer you the best possible support.

<https://www.app-therm.com/warranty-registration/>

a) **I'm experiencing problems with my chiller. It's within warranty – what do I do next?**

Contact ATC to discuss the issue you are having on +44(0)1530 839998 or support@app-therm.com. Be sure to have your model number and serial number on-hand to aid those attempting to solve remotely.

b) **Telephone support couldn't fix my chiller – what do I do next?**

An RMA form must be completed. This allows both the end-user and ATC to clarify your details, to set the party responsible for shipping costs, and to set a different return address if desired. Shipping advice is provided, and the end-user must sign a declaration that states the unit is safe to handle. Return the form by email for fastest response.

c) **What happens if my chiller failed outside warranty or requires non-warranty repair work?**

A purchase order will be requested to cover an initial inspection – this will only be invoiced if the inspection shows there is no fault. If packaging is required, i.e. a crate, a separate charge will be levied. If the end user prefers ATC to arrange a collection, a shipping charge may be levied.

d) **Our process must continue running – can we have a loan unit whilst our chiller is in repair?**

ATC hold several standard air-cooled chillers at the factory for the sole purpose of offering for loan. These are available on a first come, first-serve basis. Models up-to 3kW capacity are available.

User & Operation Manual

H-SERIES CHILLERS

| | | | | | | | | | |
|----------|-------|---------|-----|------|----------|--------|-----|------|----|
| Document | M-005 | Version | 1.1 | Date | 19/06/25 | Author | JWB | Page | 14 |
|----------|-------|---------|-----|------|----------|--------|-----|------|----|

3.0 PRODUCT SPECIFICATIONS

3.1 H03/H05 (ALL STANDARD VARIANTS)

| | | |
|---|---|---|
| Weight | H03: | 87kg 192lbs |
| | H05: | 87kg 192lbs |
| Form factor | Floor standing | |
| Dimensions | W385 x D564 x H554mm W15.2" x D22.2" x H21.8" | |
| Noise level | 76dB(A)@1m (standard fan) | |
| Toolless access | No | |
| Technology | Vapour compression | |
| Cooling capacity (Fluid setpoint +20°C, ambient temperature +20°C) | H03: | 3.4 kW 11,601 BTU/h 0.967 TR |
| | H05: | 5.5 kW 18,767 BTU/h 1.564 TR |
| Refrigerant | R454C | |
| Refrigerant charge | 1Kg | |
| Ambient temperature range (operating) | 0°C to +30°C | |
| Maximum ambient (transport/storage) | +70°C | |
| Control method | PID via solenoid valve | |
| Stability | ±0.1°C | |
| Resolution | 0.1°C | |
| Sensor type | PT100 | |
| System volume | 2.75L | |
| Pump (As per model number configuration) | H03/H05: | P5 , Rotary Vane, 5L/m P10 , Rotary Vane, 10L/m P17 , Rotary Vane, 17L/m |
| | H05 only: | P25 , Centrifugal, 25L/m |
| Pressure relief | Internal, PRV, 20-150psi (<i>PD pumps only</i>) | |
| Process fittings | 1/2" BSPPF P5/P10/P17, 1" BSPPF P25/P40/P80 | |
| Electrical supply (As per model number configuration) | 0-Spec: 230V ±10% (50Hz) 1~ 6-Spec: (switchable) 208V ±5% (60Hz) 1~/2~ 220V ±5% (60Hz) 1~/2~ 230V ±10% (50Hz) 1~ | |

User & Operation Manual

H-SERIES CHILLERS

| | | | | | | | | | |
|-----------------|-------|----------------|-----|-------------|----------|---------------|-----|-------------|----|
| Document | M-005 | Version | 1.1 | Date | 19/06/25 | Author | JWB | Page | 15 |
|-----------------|-------|----------------|-----|-------------|----------|---------------|-----|-------------|----|

| | |
|---------------------------------|---|
| | Max current draw H03: 10A H05 (standard): 14A – use with 16A plug only |
| 1 st party approvals | CE, UKCA |
| 3 rd party approvals | None |
| Empty fluid tank alarm | Visual, lamp |
| Low fluid flow alarm | Visual, lamp |
| Temp range alarm | Visual, lamp |
| Fridge HP switch | Standard |
| Motor thermal cutout | Standard |
| Overcurrent protection | Standard, via MCB |
| Overcurrent restart | Manual |
| Emergency off | Not present |
| Warranty options | 2-year parts, 1-year labor Enhanced on request |
| Rated duty cycle | S1 Continuous |

3.2 H06/H12 (ALL STANDARD VARIANTS)

| | | |
|---|---|------------------------------------|
| Weight | H06: | 155kg 342lb |
| | H12: | 167kg 368lb |
| Form factor | Floor standing | |
| Dimensions | W904 x D610 x H1180mm W35.6" x D24.1" x H46.5" | |
| Noise level | 95dB(A)@1m | |
| Toolless access | No | |
| Technology | Vapour compression | |
| Cooling capacity (Fluid setpoint +20°C, ambient temperature +20°C) | H06: | 6.5 kW 22,179 BTU/h 1.848 TR |
| | H12: | 12 kW 40,946 BTU/h 3.412 TR |
| Refrigerant | R454C | |
| Refrigerant charge | 1kg | |
| Ambient temperature range | 0°C to +30°C | |
| Control method | PID via solenoid valve | |
| Stability | ±0.1°C | |
| Resolution | 0.1°C | |
| Sensor type | PT100 | |
| System volume | 3.5L | |
| Pump | P10, Rotary Vane, 10L/m | |

User & Operation Manual

H-SERIES CHILLERS

| | | | | | | | | | |
|-----------------|-------|----------------|-----|-------------|----------|---------------|-----|-------------|----|
| Document | M-005 | Version | 1.1 | Date | 19/06/25 | Author | JWB | Page | 16 |
|-----------------|-------|----------------|-----|-------------|----------|---------------|-----|-------------|----|

| | |
|--|--|
| (As per model number configuration) | P17 , Rotary Vane, 17L/m P25 , Centrifugal, 25L/m P40 , Centrifugal, 40L/m P80 , Centrifugal, 80L/m |
| Pressure relief | Internal, PRV, 20-150psi (<i>PD pumps only</i>) |
| Process fittings | 1/2" BSPPF P10/P17, 1" BSPPF P25/P40/P80 |
| Electrical supply (As per model number configuration) | 3-Spec: 400Vac, 3~, 50Hz, MOC 16A 4-Spec: 460Vac, 3~, 60Hz, MOC 16A |
| 1 st party approvals | CE, UKCA |
| 3 rd party approvals | None |
| Empty fluid tank alarm | Visual, lamp |
| Low fluid flow alarm | Visual, lamp |
| Temp range alarm | Visual, lamp |
| Fridge HP switch | Standard |
| Motor thermal cutout | Standard |
| Overcurrent protection | Standard, via contactor |
| Overcurrent restart | Manual |
| Emergency off | Not present |
| Warranty options | 2-year parts, 1-year labor Enhanced on request |
| Rated duty cycle | S1 Continuous |

4.0 QUICK START GUIDE

| | |
|----------|---|
| 1 | Remove all the packaging (Section 1.3) |
| 2 | Connect chiller's outlet and inlet process to your application |
| 3 | Fill up the chiller with appropriate coolant |
| 4 | Use the name plate on the back of the chiller to verify the appropriate voltage and supply the power using provided cables. |
| 5 | Check the transformer voltage key-switch has been set to the required position |
| 6 | Turn the power switch ON |
| 7 | Slowly add more coolant as process lines fill and the coolant is circulated around the process system. |
| 8 | Using the controller, set the desired temperature. |

| | | | | | | | | | |
|----------|-------|---------|-----|------|----------|--------|-----|------|----|
| Document | M-005 | Version | 1.1 | Date | 19/06/25 | Author | JWB | Page | 17 |
|----------|-------|---------|-----|------|----------|--------|-----|------|----|

5.0 INSTALLATION

5.1 HOSE RECOMMENDATIONS

Having ensured that your installation meets all site requirements, it is best practice that the fluid lines between your application and the chiller have the following characteristics.

| | |
|---|--|
| 1 | Short in length – this reduces friction-based pressure drop and addition ambient heat load. |
| 2 | Large diameter bore – these should be correctly sized to the specified pump |
| 3 | Free from 90° bends – to limit the effects of water hammer. If this cannot be avoided, sharp changes of direction should be minimized so far as possible. Doing this correctly can yield higher pump performance and extend time between maintenance intervals. It will also reduce electrical energy consumption. |
| 4 | Clean – If your installation is to existing pipe work, it is good practice to flush the system with either a commercially available central heating cleaner or 5% acetic acid solution. The system should be flushed clean to remove all traces of cleaner prior to filling the system. Failing this, it is recommended to use a domestic bleach in 1:100 dilution with water. |
| 5 | Opaque, ideally black – to inhibit light passing through the tube and algae building up. Alternatively, solid ABS or copper pipe can be used where application chemistry allows. |
| 6 | Insulation, where low temperature process is planned – the process line from chiller to application contains the feed of low temperature fluid. Insulation prevents heat from entering this line and can promote better stability. Uninsulated return lines are helpful where free cooling can be obtained by allowing heat to transfer to air – likewise, insulating the return line is helpful if the fluid temperature is below ambient. |
| CAUTION | |
|  | Never use transparent tubing. UV light will pass through, prompting growth of organic contamination. |

5.2 FLUID FITTINGS

| | |
|---|---|
| 1 | Standard units are supplied with either 1/2" or 1" British Standard Pipe Parallel Female (BSPPF) threads, also known as G threads (ISO228), by default. These fittings are not valved and will 'drop' the volume of the system if left open to atmosphere. |
| 2 | Ensure the appropriate thread sealants are used in the fitting of adapters to hose. For metallic mating parts, we recommend Loctite 577. For plastic adaptors such as those supplied with the product, we recommend using ~8-12mm wide PTFE tape, wrapped around the male thread before tightening. |
| 3 | Ensure that the system is correctly connected. The 'donut' labels around the ports are clearly marked with inlet and outlet symbols and function in both English and French language. Ports marked as outlet means fluid leaves the product and must be connected to the process inlet. |
| 4 | Check all joints are tight and leak free. |

| | | | | | | | | | |
|----------|-------|---------|-----|------|----------|--------|-----|------|----|
| Document | M-005 | Version | 1.1 | Date | 19/06/25 | Author | JWB | Page | 18 |
|----------|-------|---------|-----|------|----------|--------|-----|------|----|

- | | |
|---|---|
| 5 | Where this product is incorporated into other equipment, it is the responsibility of the assembler to ensure safety |
|---|---|

5.3 BACKFILLING

CAUTION



- In situations where the chiller is situated physically lower than the application being cooled, fluid will apply pressure to the water circuit of the product.
- The weakest seal is normally the tank lid, and this is typically where fluid will escape the unit.
- Ideally, the product will be located higher or level with the product waterline. If this is not possible, a non-return solenoid valve kit can be installed as an optional standard assembly.
- Please raise any questions with the sales team on sales@app-therm.com.

5.4 VOLTAGE SELECTION

CAUTION



- Different chillers will have different requirement for electrical supply. The specification and requirement can be found on the back plate of the chiller.
- Please ensure that the voltage supply and number of phases are correct on the site and your power supply can handle the stated current draw.
- Where key-switch voltage selectors are fitted, check these have been correctly set to match your electrical supply.

5.5 FILLING PROCEDURE

- a) Check all application valves are open, including solenoid valves and variable position valves.**
 - i) The product will require an open water circuit to pump into.
 - ii) Any obstructions can increase the time, or entirely prevent the bleeding of air from the system.
- b) Remove the cap from the tank lid on the top of the product.**
 - i) Fill the tank until fluid is visible at the centre of the tank sight glass. This is the maximum fill level.
- c) Switch the unit on**

User & Operation Manual

H-SERIES CHILLERS

| | | | | | | | | | |
|----------|-------|---------|-----|------|----------|--------|-----|------|----|
| Document | M-005 | Version | 1.1 | Date | 19/06/25 | Author | JWB | Page | 19 |
|----------|-------|---------|-----|------|----------|--------|-----|------|----|

- i) Check power is connected and switched on.
- ii) Switch the unit on at the rocker switch. The pump will start running immediately.
- iii) Keep the unit running until the water level in the tank drops and cuts out on the level switch interlock.
- iv) Turn the unit off at the main switch.
- v) Fill the tank again to lift the level switch.
- vi) Start the product

CAUTION



CAUTION: Do not run the pump dry.

d) Repeat step (c) until the chiller does not cut out on the level switch.

e) Now with the unit running:

- i) Leave the cap off the tank for 20-30mins to allow air to escape, or very loosely screwed on to prevent dust & debris ingress.

f) Check the application and tubing for signs of leaks whilst the chiller is running.

- i) Replace the tank lid fully when satisfied the system is full and bled of air and no abnormal sound can be heard from the pump

5.6 DRAINING A SYSTEM

- a) Isolate the unit. Have a suitable receptacle or drain on-hand.
 - i) Remove the tank lid to allow air into the system.
 - ii) Disconnect hoses individually. Be aware hoses as well as the unit are filled with fluid.
 - iii) Use tank drain tap (where fitted).
 - iv) Consider using the red transport plugs to block product ports to give yourself time to empty hoses before continuing to empty the product.

b) Local rules affect where fluid can be disposed of.





Ensure hazardous products do not enter the water course and are reclaimed from the unit for professional disposal.

| | | | | | | | | | |
|----------|-------|---------|-----|------|----------|--------|-----|------|----|
| Document | M-005 | Version | 1.1 | Date | 19/06/25 | Author | JWB | Page | 20 |
|----------|-------|---------|-----|------|----------|--------|-----|------|----|

6.0 CONTROLLER OPERATION

6.1 KR1 CONTROLLER













The KR1 is a high performance PID controller, which can control temperature to within 0.1 °C of set point. In addition, there is a high and low temperature WARNING via the LED on the display of the controller, which is triggered if the temperature deviates more than 10 °C from the set point.

| DISPLAY CONTENTS DURING NORMAL OPERATION | |
|---|--|
|  | |
| 1 | Menu navigation button: Return |
| 2 | Menu navigation button: Up |
| 3 | Menu navigation button: Down |
| 4 | Menu navigation button: Enter |
| 5 | Setpoint value (SP) display, set by user. |
| 6 | Active output (1-4) display |
| 7 | °C or °F temperature unit display, settable in the 'inP' group. |
| 8 | Manual mode enabled display (fixed output value). |
| 9 | Alarm active display. This appears when output is beyond the set alarm point. |
| 10 | Present value (PV) display, from input sensor. |
| ACCESS TO SETTINGS | |
| 1 | Press and hold  for more than 5 seconds. The Present Value display [10] will show PASS while the Setpoint display [5] will show 0. |
| 2 | Using  and  buttons, set the programmed password – full access is granted by entering '40'. ATC are not responsible for damage either to the chiller or the connected equipment as a result of changing parameters without consulting ATC. |
| 3 | During parameter modification the instrument continues to perform process control. In certain conditions, when a configuration change can produce a significant change to the process, it is advisable to temporarily stop the controller from controlling during the programming procedure (control outputs [6] will be OFF). |





User & Operation Manual

H-SERIES CHILLERS

| | | | | | | | | | |
|-----------------|-------|----------------|-----|-------------|----------|---------------|-----|-------------|----|
| Document | M-005 | Version | 1.1 | Date | 19/06/25 | Author | JWB | Page | 21 |
|-----------------|-------|----------------|-----|-------------|----------|---------------|-----|-------------|----|

| | |
|--|---|
| | A password equal to 2000 + the programmed value (i.e. 2000 + 40 = 2040). The control will restart automatically when the configuration procedure will be manually closed. |
| 4 | Press  If the password is correct the display, will show the acronym of the first parameter group 'inP'. Press and hold  for more than 5 seconds, then the instrument will come back to the "standard display". |
| 5 | The configuration parameters are collected in various groups. Every group defines all parameters related with a specific function (control, alarms, output functions). |
| 6 | Press and hold  for more than 5 seconds, the instrument will come back to the "standard display". For specific settings and guidance, review the controller datasheets provided by ATC. If you are not in receipt of these, please contact ATC using the information in the header of this document. |
| GENERAL NAVIGATION | |
|  | A short press allows you to exit from the current parameter group and select a new parameter group. A long press allows you to close the configuration parameter procedure (the instrument will come back to the "standard display"). |
|  | When the upper display is showing a group and the lower display is blank, this key allows you to enter the selected group. When the upper display is showing a parameter and the lower display is showing its value, this key allows to store the selected value for the current parameter and access the next parameter within the same group. |
|  | Allows to increase the value of the selected parameter. |
|  | Allows to decrease the value of the selected parameter. |
|   | Pushing both  and  moves back to the previous group. Press and hold  first, then also press and hold  The selection of the group is cyclic (on a carousel), so it is possible to move back around to the group you require. |

6.2.1 CHANGING SETPOINT

| ACHIEVING DESIRED SET POINT | |
|------------------------------------|--|
| 1 | Push and hold  until it shows "SP 1" |
| 2 | Use  and  to adjust the temperature setpoint |
| 3 | Press  again to confirm the new temperature setpoint |
| 4 | The set value now will be activated, and the chiller will start |

| | | | | | | | | | |
|----------|-------|---------|-----|------|----------|--------|-----|------|----|
| Document | M-005 | Version | 1.1 | Date | 19/06/25 | Author | JWB | Page | 22 |
|----------|-------|---------|-----|------|----------|--------|-----|------|----|

6.3 REGULATING PRESSURE/FLOW (P5 to P17)

POSITIVE DISPLACEMENT PUMPS & DISCRETE PRESSURE RELIEF VALVE

This arrangement comprises a positive displacement pump (most commonly a rotary vane type) with a spring-loaded pressure relief valve to provide better overpressure setting control with minimal flow losses compared to fixed orifice bypasses/reliefs. This annex describes ATC's default settings and how to adjust the system.

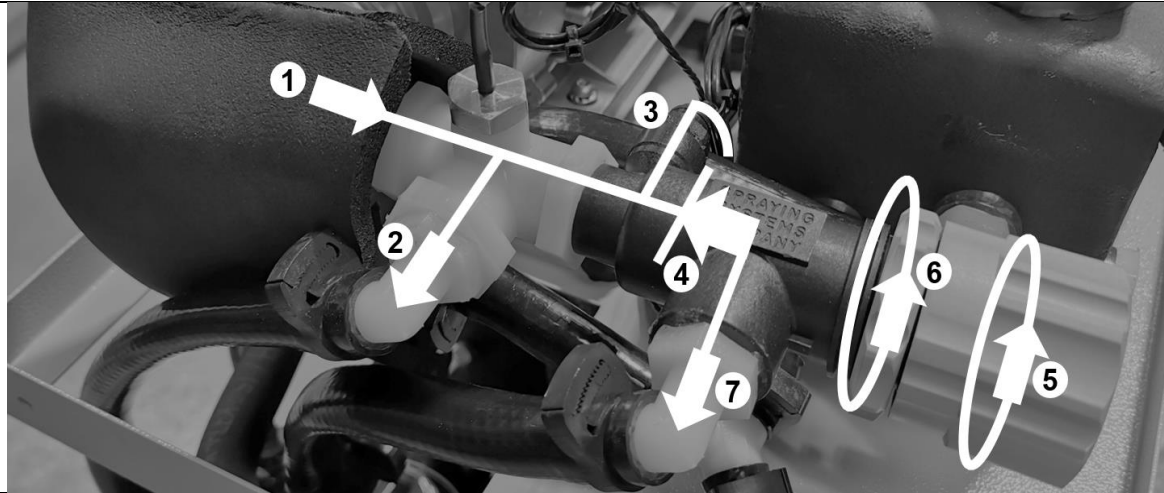

It is important to understand the basic principle that all else being equal, higher flow results in a higher demand for pressure. The motor generates the power required to turn the pump head and create that pressure. The more restrictive a water circuit is, the higher the pressure required to maintain flowrate. Positive displacement pumps are designed to generate high pressure and are mechanically tight - their RPM dictates flowrate. See image above. *(Note: the image is generic, and may not precisely match your particular chiller)*

| | |
|---|---|
| 1 | Pump discharge – fluid leaves the pump head and enters the gauge-tee assembly. It passes the temperature sensor at the tee, and when the pressure relief is inactive, fluid heads towards no. 2. |
| 2 | Outlet to process – fluid heads out of the product to the application. Whatever restrictions lie downstream, fluid leaving this point has not passed through the pressure relief valve. |
| 3 | Pressure gauge connection – connection to a pressure gauge on the front panel of the product. This displays the pressure in the water circuit, <i>at the pump outlet, not the application which will be lower.</i> |
| 4 | Pressure Relief Valve (PRV) – spring tension in the body of the PRV determines whether fluid travels through point 2 or passes through to point 7. |
| 5 | PRV adjustment knob – rotate clockwise to increase maximum delivery pressure. Rotate anti-clockwise to limit maximum delivery pressure. |
| 6 | PRV adjustment locknut – release this locknut to adjust no.5. Ensure it is tightened once adjustments are made. If it is not, vibration may cause the adjustment knob to move on itself. |

User & Operation Manual

H-SERIES CHILLERS

| | | | | | | | | | |
|----------|-------|---------|-----|------|----------|--------|-----|------|----|
| Document | M-005 | Version | 1.1 | Date | 19/06/25 | Author | JWB | Page | 23 |
|----------|-------|---------|-----|------|----------|--------|-----|------|----|

| | |
|----------|---|
| 7 | Bypass flow outlet – where the pressure requirement to overcome restrictions downstream of no.2 rises to be higher than the setting at no.5, the spring inside no.4 will compress and allow liquid to start bleeding through to no.7. It is important to understand that the nature of the spring means there can be no black and white point for pressure relief setting – the spring will slowly compress and bleed flow until all flow passes through no.7. When fully bypassing, all flow stays inside the chiller to protect the application. |
|----------|---|

| SETTING PRESSURE RELIEF VALVE | |
|---|--|
| This unit has a pre-defined PRV value set with Hexid A4 coolant @ 0°C. 35.5psi (2.45bar) deadhead pressure is preset when read from the chiller pressure gauge. If the relief valve has been interfered with and you would like to bring the chiller back to its default pressure setting. Follow the instructions below. | |
| 1 | Isolate the chiller |
| 2 | Disconnect from the application if connected - See draining process in 5.6 DRAINING A SYSTEM |
| 3 | Connect the chiller's process inlet to process outlet – a short run of insulated hose around 1-2m (3-6ft) will be adequate. Fit a gate or ball valve in-line. |
| 4 | Start the chiller and follow the fill procedure 5.5 FILLING PROCEDURE- fluid will now be running through a short loop with very low pressure required to overcome the restriction. |
| 6 | Run the chiller to achieve and maintain a process fluid temperature of 0°C |
| 7 | With the chiller running, slowly close the gate or ball valve – this simulates a blocked application – this is known as 'deadheading' the pump. Without a PRV, the pump motor would stall or hoses may detach. Observe the pressure gauge climb as you close the valve. |
| 8 | The pressure gauge will eventually stop climbing when the process outlet is fully closed – note the value; this is the setting of the PRV where all flow is bypassed. Adjust the PRV handle to set 35.5psi (2.45bar). Use the locking ring to set the handle at the desired position. |
| 9 | The P5-P17 pump heads have an internal mechanical bypass set to 60psi |
| 10 | Contact ATC if you're unsure about any of these procedures. |

| | | | | | | | | | |
|----------|-------|---------|-----|------|----------|--------|-----|------|----|
| Document | M-005 | Version | 1.1 | Date | 19/06/25 | Author | JWB | Page | 24 |
|----------|-------|---------|-----|------|----------|--------|-----|------|----|

6.4 REGULATING PRESSURE/FLOW (P25-P80)

The arrangement comprises a centrifugal or turbine type pump with typically a gate, needle or ball valve downstream of the pump discharge to throttle the pump flowrate. Without any relief, it is critical to ensure the pump is not deadheaded (no flow, and no relief). From many years of experience, ATC have found this method of maintaining a high head pressure on the pump to extend the service life and all but eliminate pump leaks. The valve is closed slowly until the desired flowrate or maximum pressure is met for the application, read from the panel-mounted pressure gauge. This section describes ATC's default settings and how to adjust the system.

It is important to understand the basic principle that all else being equal, higher flow results in a higher demand for pressure to overcome forces of friction and viscosity. The pump motor generates the motive force required to turn the pump head and create that pressure.

The more restrictive a water circuit is, the higher the pressure required to maintain flowrate. Centrifugal and turbine-type pumps are designed to generate lower pressure and higher flowrates. They are mechanically loose which usually leads to a longer lifetime in service.

| REPRESENTATIVE COMPONENT LAYOUT & FUNCTIONS | |
|---|---|
| 1 | Pump suction – centrifugal and turbine pumps are not self-priming. The suction port/inlet must be flooded by a source of liquid. This is usually the tank with water line higher than pump suction. |
| 2 | Pump discharge – connection to the application – more restrictions downstream reduce flowrate. |
| 3 | Service pressure gauge – this displays the pressure between pump discharge and throttling valve. This is normally higher than the process pressure gauge. It should never be lower than 2bar. |
| 4 | Temperature sensor – on systems where temperature control hardware is fitted, the sensor is typically in the discharge line |
| 5 | Fixed orifice throttling valve – if fully closed (fully CW) the pump is 'deadheaded' and will lead to damage in the short-term. If fully open (fully CCW), the pump is not restricted in any way – dependent on process pressure and flow requirements, the valve can be closed slowly until the desired conditions are reached. |
| 6 | Process pressure gauge – reads the pressure in the line that is created when the customer's application is connected. |
| 7 | Discharge to process –heated fluid connection to the application. |

User & Operation Manual

H-SERIES CHILLERS

| | | | | | | | | | |
|----------|-------|---------|-----|------|----------|--------|-----|------|----|
| Document | M-005 | Version | 1.1 | Date | 19/06/25 | Author | JWB | Page | 25 |
|----------|-------|---------|-----|------|----------|--------|-----|------|----|

| SETTING THE BYPASS | |
|---|--|
| Units with this type of pressure and flow control are typically shipped fully open to prevent deadheading. When the end user or commissioning engineer first runs the unit, the full force of the pump will be available without relief – if this is likely to cause damage, the valve can be closed partially, and the service pressure gauge monitored. | |
| 1 | Set the chiller/cooler running whilst connected to the application – ensure the system has been filled as bled as per 5.5 FILLING PROCEDURE |
| CAUTION | |
|  | Fully closing the gate valve during this procedure may cause internal damage to the pump. Always the valve is open to some degree. |
| 2 | Using the surface mounted process gauge, use pressure to determine flowrate – centrifugal and turbine pump flowrates can be determined by reading the pump curve. |
| 3 | Where pressure or flow is too high, the throttling valve can be closed down – where pressure or flow is too low, it can be opened. Typically ATC size pumps to provide some excess pressure availability. |
| 4 | Ensure the service pressure gauge is always at a minimum of 2bar. |

| | | | | | | | | | |
|----------|-------|---------|-----|------|----------|--------|-----|------|----|
| Document | M-005 | Version | 1.1 | Date | 19/06/25 | Author | JWB | Page | 26 |
|----------|-------|---------|-----|------|----------|--------|-----|------|----|

7.0 BASIC TROUBLESHOOTING

| # | SYMPTOM | CAUSES |
|---|---|--|
| 1 | Compressor or pump motor not running, control illuminated. | Level switch may have been tripped – Fill the tank up again to resolve the issue |
| | | High pressure switch may have been tripped: <ul style="list-style-type: none"> a) Assess whether the ambient temperature is too high. b) Assess whether ventilation/air circulation is poor. c) Assess whether surrounding equipment is generating hot air and feeding it into the chiller air intakes. |
| | | If fitted, a low-pressure switch may have tripped – this indicates refrigerant loss. A multimeter is required to test this. |
| | | If running at a high setpoint, or if operating conditions have changed and raised the fluid temperature, it is possible the compressor has turned itself on high temperature internal protection. |
| | | Air-cooled models only: Check fan spins freely and that condenser is clear of debris. |
| | | Water-cooled models only: <ul style="list-style-type: none"> a) Check for sufficient flowrate and pressure of house water. b) Assess whether the house water temperature is too high. c) Assess whether any fouling of condenser plate heat exchanger has occurred. d) Assess whether new equipment has been added to a shared water supply and contributed to either a lack of water flow (through flow splitting) or whether additional thermal load has been added to the central water's chiller/cooler |
| 2 | Noisy Operation | Pump motor or fan motor bearings may have failed. |
| | | Pump head vane or seal may have failed. |
| | | In a 3-phase system, phase rotation may be incorrect. |
| 3 | High fluid pressure/low flow rate | Fluid lines may have become fouled through solid debris or biological growth. <ul style="list-style-type: none"> a) Ensure biocides or pre-mixed biocidal process fluids are being used. b) Ensure hoses are not transparent or translucent – UV light entering prompts growth. |
| | | General fluid leak can lead to flow rate failure. |
| | | Excess fittings, too many sharp direction changes, too small a diameter hose for flowrate or hoses too long at the wrong diameter. |
| | | |
| 4 | Fluid collecting or leaking | Leaks are impossible to diagnose remotely, but usually you will see a pool of fluid on a lower surface. Do not confuse this with condensation from cold parts of the fridge. |
| | | Review the chemical compatibility of your fluid with the chiller. Contact ATC if you are unsure. |
| 5 | Poor Cooling Performance | Excess thermal load applied <ul style="list-style-type: none"> a) Assess whether the ambient temperature is too high. |

User & Operation Manual

H-SERIES CHILLERS

| | | | | | | | | | |
|-----------------|-------|----------------|-----|-------------|----------|---------------|-----|-------------|----|
| Document | M-005 | Version | 1.1 | Date | 19/06/25 | Author | JWB | Page | 27 |
|-----------------|-------|----------------|-----|-------------|----------|---------------|-----|-------------|----|

| | |
|--|--|
| | b) Assess whether ventilation/air circulation is poor. c) Assess whether surrounding equipment is generating hot air and feeding it into the chiller air intakes. |
| | Air-cooled models only: d) Check if the fans are running. e) Clean the condenser coil. |
| | Water-cooled models only: d) Assess whether house water temperature is too high. e) Assess whether house water flowrate is too low. |
| Please contact ATC if you could not find the information you were looking for or still have an issue with the unit | |

CAUTION



| | |
|---|---|
|  | Leaks from positive displacement pumps (P5-P17): |
| | <ul style="list-style-type: none">• Fluid leaks cannot be fully eliminated due to the nature of the pump's construction.• A leak rate of up to 0.05cc/hr would be considered normal.• The pump head is considered a wear part, its lifespan will be significantly reduced if cavitation occurs. |

User & Operation Manual

H-SERIES CHILLERS





| | | | | | | | | | |
|----------|-------|---------|-----|------|----------|--------|-----|------|----|
| Document | M-005 | Version | 1.1 | Date | 19/06/25 | Author | JWB | Page | 28 |
|----------|-------|---------|-----|------|----------|--------|-----|------|----|

8.0 END USER MAINTENANCE

| ⚠ WARNING | | | | | | | | | | | | |
|---|---|--------|--------|--------|----|----|---|---|---|---|---|---|
|  | Safely isolate your product prior to commencing any cleaning or maintenance tasks. | | | | | | | | | | | |
| CAUTION | | | | | | | | | | | | |
|  | <ul style="list-style-type: none"> • Failure to carry out service at the specified intervals may permanently damage your equipment. • Never blow out the condenser with compressed air (air-cooled units only). • If the main lead is lost or damaged, contact ATC who will be able to supply a replacement to the correct specification. • It is recommended that a full service and refrigerant circuit leak test of the appliance is conducted every 6 months by engineers qualified in the handling of hydrocarbon refrigerants. | | | | | | | | | | | |
| Print this sheet out and display close to the chiller to maximize the visibility of maintenance requirements. | | | | | | | | | | | | |
| Weekly | Week 1 | Week 2 | Week 3 | Week 4 | | | | | | | | |
| Check Fluid Level – Top up as required | | | | | | | | | | | | |
| Monthly | J | F | M | A | M | J | J | A | S | O | N | D |
| <i>Air-cooled only:</i> Check the condenser is free from dust or accumulation of debris | | | | | | | | | | | | |
| Annually | Y1 | Y2 | Y3 | Y4 | Y5 | Y6 | | | | | | |
| Drain process fluid and replace with fresh fluid | | | | | | | | | | | | |
| Check for fluid leaks throughout chiller and application | | | | | | | | | | | | |
| Clear any debris from inside the chiller | | | | | | | | | | | | |
| A vacuum cleaner is recommended for cleaning out the condenser (air cooled units only). Soft cloths and IPA are recommended for cleaning metallic surfaces. If any spillages have occurred, allow the water to evaporate and wipe up remaining glycol residue with a cloth. | | | | | | | | | | | | |

| | | | | | | | | | |
|----------|-------|---------|-----|------|----------|--------|-----|------|----|
| Document | M-005 | Version | 1.1 | Date | 19/06/25 | Author | JWB | Page | 29 |
|----------|-------|---------|-----|------|----------|--------|-----|------|----|

9.0 DECLARATION OF CONFORMITY

| | | |
|--|---|---|
|  |  |  |
| EU DECLARATION OF CONFORMITY / UK CONFORMITY ASSESSED | | |
| Applied Thermal Control Ltd, 39 Hayhill Industrial Estate, Barrow-upon-Soar, Loughborough, LE12 8LD, UK. Tel +44 (0)1530 83 99 98. www.app-therm.com | | |
| We hereby declare in sole responsibility that the following product; | | |
| Product: | Recirculating Chiller | |
| Product range: | Prefix H | |
| Serial number: | <input type="text"/> | |
| Is compliant with the following directives: | Machinery Directive 2006/42/EC EMC Directive 2004/108/EC Low Voltage Directive 2014/35/EU RoHS Directive 2011/65/EU ⁽¹⁾ | |
| Is compliant with the following harmonized standards: | ⁽¹⁾ Including substances added by Commission Delegated Directive (EU) 2015/863 EN ISO 12100:2010 General principles for design — Risk assessment and risk reduction EN 378-1:2016+A1:2020 Refrigerating systems and heat pumps. Safety and environmental requirements - Basic requirements, definitions, classification and selection criteria EN 378-2:2016+A1:2020 Refrigerating systems and heat pumps. Safety and environmental requirements - Design, construction, testing, marking and documentation EN 61010-1:2010+A1:2019 Safety requirements for electrical equipment for measurement, control, and laboratory use - General requirements IEC 61000-6-2:2005 Electromagnetic compatibility (EMC) - Immunity for industrial environments IEC 61000-6-4:2006 +A1:2011 Electromagnetic compatibility (EMC) - Emission standard for industrial environments | |
| Quality assurance system: | Citation ISO Certification, Muspole Court, Muspole Street, Norwich, NR3 1DJ, United Kingdom. ASCB Registered; 201409-2 | |
| Authorized representative in charge of administering technical documentation: | Atik Cameras Unipessoal Lda. Rua Horta dos Baceiros, 15 2690-390 Santa Iria da Azoia Portugal | |
| Person empowered to draw up declaration: |  | |
| Place and date: | Barrow-Upon-Soar, UK, 19/06/2025 | |
| Name and function: | Robert Poniatowski, Managing Director | |



| | | | | | | | | | |
|-----------------|-------|----------------|-----|-------------|----------|---------------|-----|-------------|----|
| Document | M-005 | Version | 1.1 | Date | 19/06/25 | Author | JWB | Page | 30 |
|-----------------|-------|----------------|-----|-------------|----------|---------------|-----|-------------|----|

10.0 REFRIGERANT & HEAT TRANSFER FLUID SAFETY DATA SHEETS

Safety Data Sheets in the below sections for the refrigerant used in your product, along with ATC heat transfer fluids. For further information on which heat transfer fluid is best for your application, please contact Applied Thermal Control.

| | | | | | | | | | |
|----------|-------|---------|-----|------|----------|--------|-----|------|----|
| Document | M-005 | Version | 1.1 | Date | 19/06/25 | Author | JWB | Page | 31 |
|----------|-------|---------|-----|------|----------|--------|-----|------|----|

10.1 R454C SAFETY DATA SHEET

| | | |
|--|---|--|
|  | SAFETY DATA SHEET REFRIGERANT R454C | Page: 1 Compilation date: 21/03/2017 Revision date: 26/06/2019 Revision No: 1.1 |
| Section 1: Identification of the substance/mixture and of the company/undertaking | | |
| 1.1. Product identifier | | |
| Product name: REFRIGERANT R454C REACH registered number(s): MIXTURE Product code: R454C Synonyms: OPTEON XL20 | | |
| 1.2. Relevant identified uses of the substance or mixture and uses advised against | | |
| Use of substance / mixture: * Refrigerant | | |
| 1.3. Details of the supplier of the safety data sheet | | |
| Company name: National Refrigerants Ltd 4 Watling Close Sketchley Meadows Business Park Hinckley Leicestershire LE10 3EZ United Kingdom Tel: 01455 630790 Fax: 01455 630791 Email: sds@nationalref.com | | |
| 1.4. Emergency telephone number | | |
| Emergency tel: Carechem24 +44 (0)1865 407333 | | |
| Section 2: Hazards identification | | |
| 2.1. Classification of the substance or mixture | | |
| Classification under CLP: Flam. Gas 1: H220; Press. Gas: H280 Most important adverse effects: Extremely flammable gas. Contains gas under pressure; may explode if heated. | | |
| 2.2. Label elements | | |
| Label elements: Hazard statements: H220: Extremely flammable gas. H280: Contains gas under pressure; may explode if heated. Hazard pictograms: GHS02: Flame GHS04: Gas cylinder | | |
|   | | |
| [cont...] | | |

| | | | | | | | | | |
|----------|-------|---------|-----|------|----------|--------|-----|------|----|
| Document | M-005 | Version | 1.1 | Date | 19/06/25 | Author | JWB | Page | 32 |
|----------|-------|---------|-----|------|----------|--------|-----|------|----|

SAFETY DATA SHEET

REFRIGERANT R454C

Page: 2

Signal words: Danger

Precautionary statements: P210: Keep away from heat, hot surfaces, sparks, open flames and other ignition sources.

No smoking.

P377: Leaking gas fire: Do not extinguish, unless leak can be stopped safely.

P381: Eliminate all ignition sources if safe to do so.

P410+403: Protect from sunlight. Store in a well-ventilated place.

2.3. Other hazards

Other hazards: In use, may form flammable / explosive vapour-air mixture.

PBT: This product is not identified as a PBT/vPvB substance.

Section 3: Composition/information on ingredients

3.2. Mixtures

Hazardous ingredients:

2,3,3,3-TETRAFLUOROPROP-1-EN - REACH registered number(s): 01-0000019665-61

| EINECS | CAS | PBT / WEL | CLP Classification | Percent |
|-----------|----------|--|-------------------------------------|---------|
| 468-710-7 | 754-12-1 | Substance with a Community workplace exposure limit. | Flam. Gas 1: H220; Press. Gas: H280 | 78.500% |

REFRIGERANT R32 - REACH registered number(s): 01-2119471312-47

| | | | | |
|-----------|---------|--|--|---------|
| 200-839-4 | 75-10-5 | Substance with a Community workplace exposure limit. | Flam. Gas 1: H220; Press. Gas: H280; -: EUH044 | 21.500% |
|-----------|---------|--|--|---------|

Section 4: First aid measures

4.1. Description of first aid measures

Skin contact: Remove all contaminated clothes and footwear immediately unless stuck to skin. Drench the affected skin with running water for 10 minutes or longer if substance is still on skin. Do not use hot water. If frostbite has occurred call a physician.

Eye contact: Bathe the eye with running water for 15 minutes. Consult a doctor.

Ingestion: Ingestion is unlikely due to its physical properties and is not expected to be dangerous. Since this product is a gas, refer to the inhalation section.

Inhalation: Remove casualty from exposure ensuring one's own safety whilst doing so. If unconscious, check for breathing and apply artificial respiration if necessary. Consult a doctor.

4.2. Most important symptoms and effects, both acute and delayed

Skin contact: There may be redness or whiteness of the skin in the area of exposure. Frost-bite may occur causing the affected area to become white and numb.

Eye contact: There may be pain and redness. Corneal burns may occur. May cause permanent damage.

Ingestion: Ingestion is unlikely due to the physical properties of the product. As product is a gas refer to inhalation section.

Inhalation: Inhalation may produce the following symptoms: Shortness of breath, dizziness, weakness, nausea, headache, narcosis, irregular cardiac activity.

[cont...]

| | | | | | | | | | |
|----------|-------|---------|-----|------|----------|--------|-----|------|----|
| Document | M-005 | Version | 1.1 | Date | 19/06/25 | Author | JWB | Page | 33 |
|----------|-------|---------|-----|------|----------|--------|-----|------|----|

SAFETY DATA SHEET

REFRIGERANT R454C

Page: 3

4.3. Indication of any immediate medical attention and special treatment needed

Immediate / special treatment: Not applicable.

Section 5: Fire-fighting measures

5.1. Extinguishing media

Extinguishing media: Suitable extinguishing media for the surrounding fire should be used. Alcohol resistant foam. Water spray. Carbon dioxide. Dry chemical powder. Use water spray to cool containers.

5.2. Special hazards arising from the substance or mixture

Exposure hazards: Flammable. In combustion emits toxic fumes. Forms explosive air-vapour mixture.

5.3. Advice for fire-fighters

Advice for fire-fighters: Wear self-contained breathing apparatus. Wear protective clothing to prevent contact with skin and eyes.

Section 6: Accidental release measures

6.1. Personal precautions, protective equipment and emergency procedures

Personal precautions: Refer to section 8 of SDS for personal protection details. Eliminate all sources of ignition. If outside keep bystanders upwind and away from danger point.

6.2. Environmental precautions

Environmental precautions: Stop release if safe to do so. Prevent from entering sewers, basements and work pits, or any place where the accumulation can be dangerous.

6.3. Methods and material for containment and cleaning up

Clean-up procedures: Do not use equipment in clean-up procedure which may produce sparks. Material evaporates. Ventilate the area, especially low or enclosed places where heavy vapours might collect.

6.4. Reference to other sections

Reference to other sections: Refer to section 8 of SDS.

Section 7: Handling and storage

7.1. Precautions for safe handling

Handling requirements: Smoking is forbidden. Use non-sparking tools. Ensure there is sufficient ventilation of the area. Avoid the formation or spread of mists in the air.

7.2. Conditions for safe storage, including any incompatibilities

Storage conditions: Store in a cool, well ventilated area. Keep container tightly closed. Keep away from sources of ignition. Prevent the build up of electrostatic charge in the immediate area. Ensure lighting and electrical equipment are not a source of ignition.

Suitable packaging: Must only be kept in original packaging.

[cont...]

| | | | | | | | | | |
|----------|-------|---------|-----|------|----------|--------|-----|------|----|
| Document | M-005 | Version | 1.1 | Date | 19/06/25 | Author | JWB | Page | 34 |
|----------|-------|---------|-----|------|----------|--------|-----|------|----|

SAFETY DATA SHEET

REFRIGERANT R454C

Page: 4

7.3. Specific end use(s)

Specific end use(s): No data available.

Section 8: Exposure controls/personal protection

8.1. Control parameters

Hazardous ingredients:

2,3,3,3-TETRAFLUOROPROP-1-EN

Workplace exposure limits:

Respirable dust

| State | 8 hour TWA | 15 min. STEL | 8 hour TWA | 15 min. STEL |
|-------|------------|--------------|------------|--------------|
| EU | 500 ppm | - | - | - |

REFRIGERANT R32

| | | | | |
|----|----------|---|---|---|
| UK | 1000 ppm | - | - | - |
|----|----------|---|---|---|

DNEL/PNEC Values

Hazardous ingredients:

2,3,3,3-TETRAFLUOROPROP-1-EN

| Type | Exposure | Value | Population | Effect |
|------|-----------------------|-----------------------|------------|--------|
| DNEL | Inhalation | 273 mg/m ³ | Workers | - |
| PNEC | Fresh water | > 0.1 mg/l | - | - |
| PNEC | Marine water | > 0.01 mg/l | - | - |
| PNEC | Fresh water sediments | > 1.77 mg/kg | - | - |
| PNEC | Soil (agricultural) | > 1.54 mg/kg | - | - |

REFRIGERANT R32

| Type | Exposure | Value | Population | Effect |
|------|--------------------------------|-------------------------|------------|----------|
| DNEL | Inhalation (developmental tox) | 13936 mg/m ³ | Workers | Systemic |
| DNEL | Inhalation (developmental tox) | 2476 mg/m ³ | Consumers | Systemic |
| PNEC | Fresh water | 0.142 mg/l | - | - |
| PNEC | Fresh water sediments | 0.534 mg/kg | - | - |

8.2. Exposure controls

Engineering measures: Ensure there is sufficient ventilation of the area. Ensure lighting and electrical equipment are not a source of ignition.

Respiratory protection: Respiratory protection not required.

Hand protection: Protective gloves. The suitability for a specific workplace should be discussed with the producers of the protective gloves.

Eye protection: Safety glasses with side-shields. Safety goggles. Face-shield. Ensure eye bath is to hand.

Skin protection: Protective clothing.

Environmental: Gas escapes to be kept to the minimum by engineering processes and operating methods.

[cont...]

| | | | | | | | | | |
|----------|-------|---------|-----|------|----------|--------|-----|------|----|
| Document | M-005 | Version | 1.1 | Date | 19/06/25 | Author | JWB | Page | 35 |
|----------|-------|---------|-----|------|----------|--------|-----|------|----|

SAFETY DATA SHEET REFRIGERANT R454C

Page: 5

Section 9: Physical and chemical properties

9.1. Information on basic physical and chemical properties

| | |
|--|---|
| State: Liquified gas | |
| Colour: Colourless | |
| Odour: Characteristic odour | |
| Evaporation rate: Fast | |
| Solubility in water: No data available. | |
| Boiling point/range°C: -45.9 | Melting point/range°C: No data available. |
| Flammability limits %: lower: >7 | upper: < 15 |
| Flash point°C: Not applicable. | Part.coeff. n-octanol/water: Not applicable. |
| Autoflammability°C: 444 | Vapour pressure: 11.691 hPa |
| Relative density: 0.99 @ 25 degC | pH: No data available. |

9.2. Other information

Other information: R454C Vapour Dencity: 3.2 (Air = 1)

Section 10: Stability and reactivity

10.1. Reactivity

Reactivity: Stable under recommended transport or storage conditions.

10.2. Chemical stability

Chemical stability: Stable under normal conditions. Stable at room temperature.

10.3. Possibility of hazardous reactions

Hazardous reactions: Hazardous reactions will not occur under normal transport or storage conditions.
Decomposition may occur on exposure to conditions or materials listed below.

10.4. Conditions to avoid

Conditions to avoid: Heat. Hot surfaces. Sources of ignition. Flames.

10.5. Incompatible materials

Materials to avoid: Strong oxidising agents. Strong acids.

10.6. Hazardous decomposition products

Haz. decomp. products: In combustion emits toxic fumes.

Section 11: Toxicological information

11.1. Information on toxicological effects

[cont...]

| | | | | | | | | | |
|----------|-------|---------|-----|------|----------|--------|-----|------|----|
| Document | M-005 | Version | 1.1 | Date | 19/06/25 | Author | JWB | Page | 36 |
|----------|-------|---------|-----|------|----------|--------|-----|------|----|

SAFETY DATA SHEET REFRIGERANT R454C

Page: 6

Hazardous ingredients:

2,3,3,3-TETRAFLUOROPROP-1-EN

| | | | | |
|-------|-----|---------|----------|------|
| GASES | RAT | 4H LC50 | > 400000 | ppmV |
|-------|-----|---------|----------|------|

REFRIGERANT R32

| | | | | |
|-------|-----|------|--------|------|
| GASES | RAT | LD50 | 520000 | ppmV |
|-------|-----|------|--------|------|

Toxicity values: No data available.

Symptoms / routes of exposure

Skin contact: There may be redness or whiteness of the skin in the area of exposure. Frost-bite may occur causing the affected area to become white and numb.

Eye contact: There may be pain and redness. Corneal burns may occur. May cause permanent damage.

Ingestion: Ingestion is unlikely due to the physical properties of the product. As product is a gas refer to inhalation section.

Inhalation: Inhalation may produce the following symptoms: Shortness of breath, dizziness, weakness, nausea, headache, narcosis, irregular cardiac activity.

Section 12: Ecological information

12.1. Toxicity

Hazardous ingredients:

2,3,3,3-TETRAFLUOROPROP-1-EN

| | | | |
|---------------|-----------|-------|------|
| ALGAE | 96H LC50 | > 100 | mg/l |
| Daphnia magna | 48H EC50 | > 83 | mg/l |
| FISH | 96H ErC50 | >197 | mg/l |

REFRIGERANT R32

| | | | |
|---------------|-----------|-------|------|
| ALGAE | 96H ErC50 | 142 | mg/l |
| Daphnia magna | 48H EC50 | 652 | mg/l |
| FISH | 96H LC50 | 1.057 | mg/l |

12.2. Persistence and degradability

Persistence and degradability: Biodegradable.

12.3. Bioaccumulative potential

Bioaccumulative potential: No bioaccumulation potential.

12.4. Mobility in soil

Mobility: Readily absorbed into soil.

[cont..]

| | | | | | | | | | |
|----------|-------|---------|-----|------|----------|--------|-----|------|----|
| Document | M-005 | Version | 1.1 | Date | 19/06/25 | Author | JWB | Page | 37 |
|----------|-------|---------|-----|------|----------|--------|-----|------|----|

SAFETY DATA SHEET

REFRIGERANT R454C

Page: 7

12.5. Results of PBT and vPvB assessment

PBT identification: This product is not identified as a PBT/vPvB substance.

12.6. Other adverse effects

Other adverse effects: Negligible ecotoxicity.

Section 13: Disposal considerations

13.1. Waste treatment methods

Disposal operations: Product evaporates.

Recovery operations: Consult manufacturer or supplier for information regarding recovery and recycling of the product. If recovery is not possible, incinerate at a licensed installation.

Disposal of packaging: Return to supplier.

NB: The user's attention is drawn to the possible existence of regional or national regulations regarding disposal.

Section 14: Transport information

14.1. UN number

UN number: UN3161

14.2. UN proper shipping name

Shipping name: LIQUEFIED GAS, FLAMMABLE, N.O.S.
(2,3,3,3-TETRAFLUOROPROP-1-EN; DIFLUOROMETHANE)

14.3. Transport hazard class(es)

Transport class: 2

14.4. Packing group

14.5. Environmental hazards

Environmentally hazardous: No

Marine pollutant: No

14.6. Special precautions for user

Special precautions: No special precautions.

Tunnel code: B/D

Transport category: 2

Section 15: Regulatory information

15.1. Safety, health and environmental regulations/legislation specific for the substance or mixture

Specific regulations: Contains fluorinated greenhouse gases covered by the Kyoto Protocol.

15.2. Chemical Safety Assessment

Chemical safety assessment: A chemical safety assessment has not been carried out for the substance or the mixture by the supplier.

[cont...]

| | | | | | | | | | |
|----------|-------|---------|-----|------|----------|--------|-----|------|----|
| Document | M-005 | Version | 1.1 | Date | 19/06/25 | Author | JWB | Page | 38 |
|----------|-------|---------|-----|------|----------|--------|-----|------|----|

SAFETY DATA SHEET
REFRIGERANT R454C

Page: 8

Section 16: Other information

Other information

Other information: This safety data sheet is prepared in accordance with Commission Regulation (EU) No 2015/830.

* indicates text in the SDS which has changed since the last revision.

Phrases used in s.2 and s.3: EUH044: Risk of explosion if heated under confinement.

H220: Extremely flammable gas.

H280: Contains gas under pressure; may explode if heated.

Legal disclaimer: National Refrigerants Ltd believes that the information and recommendations contained herein (including data and statements) are accurate as of the date hereof. NO WARRANTY OF FITNESS FOR ANY PARTICULAR PURPOSE, WARRANTY OF MERCHANTABILITY, OR ANY OTHER WARRANTY, EXPRESSED OR IMPLIED, IS MADE CONCERNING THE INFORMATION PROVIDED HEREIN. The information provided herein relates only to the specific product designated. National Refrigerants expressly disclaims any and all liability as to any results obtained or arising from any use of the product or reliance on such information.

[final page]

| | | | | | | | | | |
|----------|-------|---------|-----|------|----------|--------|-----|------|----|
| Document | M-005 | Version | 1.1 | Date | 19/06/25 | Author | JWB | Page | 39 |
|----------|-------|---------|-----|------|----------|--------|-----|------|----|

10.2 HEXID A4 SAFETY DATA SHEET

| | | | | | |
|--|--|--|------------|---|---|
| Applied Thermal Control Ltd 39 Hayhill Industrial Estate Barrow upon Soar, Leicestershire LE12 8LD, United Kingdom | | SAFETY DATA SHEET HEXID A4 HEAT TRANSFER FLUID Conforming to Directive 1907/2006/EC | |  | |
| Issue | 6.7 | Date | April 2025 | Page | 1 |
| SECTION 1: IDENTIFICATION OF THE SUBSTANCE/MIXTURE AND OF THE COMPANY/UNDERTAKING | | | | | |
| 1.1 | Product Name | Hexid A4 | | | |
| 1.2 | Intended/Recommended Use | Heat Transfer Fluid | | | |
| 1.3 | Manufacturer | Applied Thermal Control Limited 39 Hayhill Industrial Estate, Barrow upon Soar, Leicestershire, LE12 8LD, United Kingdom. www.app-therm.com | | | |
| 1.4 | Emergency Telephone Number | +44(0)1530 839998 | | | |
| 1.5 | Email | sales@app-therm.com | | | |
| SECTION 2: HAZARDS IDENTIFICATION | | | | | |
| 2.1 | Classification of the substance or mixture | The product is not classified as dangerous according to Regulation (EC) No. 1272/2008. This mixture is not classified as dangerous according to Directive 1999/45/EC. This mixture has no classification under CLP | | | |
| 2.2 | Label elements | Label elements: This product has no label elements Signal Word: No signal word. Hazard statements: No known significant effects or critical hazards. Precautionary statements: Prevention, Response, Storage or Disposal: Not applicable. | | | |
| 2.3 | Other hazards | PBT: This product is not identified as a PBT/vPvB substance. | | | |
| SECTION 3: COMPOSITION/INFORMATION ON INGREDIENTS | | | | | |
| 3.1 | Chemical Nature | Water (CAS 7732-18-5), not classified. Propylene glycol (CAS 57-55-6) (REACH 01-2119456809-23) (EINECS 200-338-0) not classified. Fluorescein (trace) and biocide (trace) not classified. | | | |
| 3.2 | Food Grade | Food Grade | | | |
| SECTION 4: FIRST AID MEASURES | | | | | |
| General advice | | No special precautions required. Treat symptomatically. | | | |
| 4.1 | Eye Contact | Rinse thoroughly with plenty of water, also under the eyelids. Remove contact lenses after a few minutes and continue rinsing. If symptoms persist, call a physician. | | | |
| 4.2 | Skin Contact | Wash off immediately with plenty of water. If skin irritation persists, call a physician. | | | |
| 4.3 | Inhalation | Remove to fresh air. If symptoms persist, call a physician. | | | |
| 4.4 | Ingestion | Rinse mouth with water. Never give anything by mouth to an unconscious person. If symptoms persist, call a physician. | | | |

User & Operation Manual

H-SERIES CHILLERS

| | | | | | | | | | |
|----------|-------|---------|-----|------|----------|--------|-----|------|----|
| Document | M-005 | Version | 1.1 | Date | 19/06/25 | Author | JWB | Page | 40 |
|----------|-------|---------|-----|------|----------|--------|-----|------|----|

| | | | | | |
|---|---------------------------------------|---|------------|---|---|
| Applied Thermal Control Ltd 39 Hayhill Industrial Estate Barrow upon Soar, Leicestershire LE12 8LD, United Kingdom | | SAFETY DATA SHEET HEXID A4 HEAT TRANSFER FLUID Conforming to Directive 1907/2006/EC | |  | |
| Issue | 6.7 | Date | April 2025 | Page | 2 |
| SECTION 5: FIREFIGHTING MEASURES | | | | | |
| 5.1 | Extinguishing media | Use extinguishing measures that are appropriate to local circumstances and the surrounding environment. Water spray, foam, dry powder or CO ₂ . Alcohol-resistant foam | | | |
| 5.2 | Unsuitable extinguishing Media | High volume water jet. Do not use a solid water stream as it may scatter and spread fire. | | | |
| 5.3 | Specific hazards during firefighting | In fire conditions, toxic decomposition products may be formed (see also section 10). In combustion, emits fumes, smoke, carbon dioxide (CO ₂) and carbon monoxide (CO). Heating will cause a pressure rise - with severe risk of bursting and explosion, Violent steam generation or eruption may occur upon application of direct water to hot liquids. | | | |
| 5.4 | Advice for firefighters | In the event of fire, wear self-contained breathing apparatus. Wear personal protective equipment. Promptly isolate the scene by removing all persons from the vicinity of the incident if there is a fire. Keep containers cool by spraying with water if exposed to fire. Collect contaminated fire extinguishing water separately. This must not be discharged into drains. Burning fluids may be extinguished by dilution with water. | | | |
| SECTION 6: ACCIDENTAL RELEASE MEASURES | | | | | |
| 6.1 | Personal precautions | Use personal protective equipment. Avoid contact with skin and eyes. Keep unnecessary and unprotected personnel from entering the area. | | | |
| 6.2 | Precaution to protect the environment | Do not flush into surface water or sanitary sewer system. Avoid subsoil penetration. | | | |
| 6.3 | Clean-up procedures | Contain the spillage, soak up with non-combustible absorbent material, (e.g. sand, earth, diatomaceous earth, vermiculite) and transfer to a container for disposal according to local/national regulations (see section 13). Keep in suitable, closed containers for disposal. Dike the area of spill to prevent spreading and pump liquid to salvage tank. Treat recovered material as described in section 13 Disposal considerations. | | | |
| SECTION 7: HANDLING AND STORAGE | | | | | |
| 7.1 | Precautions for safe handling | Keep container tightly closed. Handle in accordance with good industrial hygiene and safety practice. Spills of these organic materials on hot fibrous insulations may lead to lowering of the auto-ignition temperatures possibly resulting in spontaneous combustion. | | | |
| 7.2 | Conditions for safe storage | Keep only in the original container. | | | |
| SECTION 8: EXPOSURE CONTROLS/PERSONAL PROTECTION | | | | | |

| | | | | | | | | | |
|----------|-------|---------|-----|------|----------|--------|-----|------|----|
| Document | M-005 | Version | 1.1 | Date | 19/06/25 | Author | JWB | Page | 41 |
|----------|-------|---------|-----|------|----------|--------|-----|------|----|

Applied Thermal Control Ltd
39 Hayhill Industrial Estate
Barrow upon Soar, Leicestershire
LE12 8LD, United Kingdom

SAFETY DATA SHEET HEXID A4 HEAT TRANSFER FLUID

Conforming to Directive 1907/2006/EC



Issue 6.7 Date April 2025 Page 3

| | |
|---|--|
| 8.1 Control Parameters | <p>Component: Propane-1,2-diol CAS-No. 57-55-6 Other Occupational Exposure Limit Values EH40 WEL, Time Weighted Average (TWA): Total vapour and particulates.150 ppm, 474 mg/m³ EH40 WEL, Time Weighted Average (TWA): Particulate.10 mg/m³ ELV (IE), Time Weighted Average (TWA): Total vapour and particulates.150 ppm, 470 mg/m³ ELV (IE), Time Weighted Average (TWA): Particulate.10 mg/m³</p> |
| 8.2 Exposure controls/Appropriate engineering controls | <p>Local exhaust. If this product contains ingredients with exposure limits, use process enclosures, local exhaust ventilation or other engineering controls to keep worker exposure below any recommended or statutory limits.</p> |
| Personal protective equipment | <p>Respiratory protection: Suitable respiratory protective device Combination filter: A-P2 Filter Type: Combined particulates and organic vapour type Hand protection: Category short time exposure - Break through time> 10 min Protective index: Class 1 When prolonged exposure is expected: Break through time> 120 min Protective index: Class 4 Observe the information of the glove manufacturers on permeability. Protective gloves should be chosen according to Workplace Safety Assessment. Gloves recommended according to EN 374 (protection against chemicals). Material: Chemical resistant gloves made of butyl rubber or nitrile rubber category III according to EN 374.</p> |

SECTION 9: PHYSICAL AND CHEMICAL PROPERTIES

| | |
|---|--------------------------------|
| 9.1 Appearance at 20°C | Fluorescent green clear liquid |
| 9.2 Odour | Almost odourless |
| 9.3 Flash Point | Boils without flashing |
| 9.4 Ignition Temperature | Not available |
| 9.5 Flammability Limit | Not available |
| 9.6 Oxidizing Properties | Not available |
| 9.7 Auto flammability | 450°C |
| 9.8 Density at 25°C | ~1.036g/cm ³ |
| 9.9 pH (as is) | 9.4 |
| 9.10 Boiling point | 102°C |
| 9.11 Solubility in water | Miscible |
| 9.12 Freezing point | -21°C |
| 9.13 Specific Heat Capacity | 3.78kJ/kg *K |
| 9.14 Viscosity, Kinetic, at 25°C | 3.51mPas |

| | | | | | | | | | |
|----------|-------|---------|-----|------|----------|--------|-----|------|----|
| Document | M-005 | Version | 1.1 | Date | 19/06/25 | Author | JWB | Page | 42 |
|----------|-------|---------|-----|------|----------|--------|-----|------|----|

Applied Thermal Control Ltd
39 Hayhill Industrial Estate
Barrow upon Soar, Leicestershire
LE12 8LD, United Kingdom

SAFETY DATA SHEET HEXID A4 HEAT TRANSFER FLUID

Conforming to Directive 1907/2006/EC



| | | | | | |
|-------|-----|------|------------|------|---|
| Issue | 6.7 | Date | April 2025 | Page | 4 |
|-------|-----|------|------------|------|---|



SECTION 10: STABILITY AND REACTIVITY

| | | |
|------|----------------------------------|--|
| 10.1 | Reactivity | Stable under recommended storage conditions. No dangerous reaction known under conditions of normal use. |
| 10.2 | Chemical stability | No decomposition if stored and applied as directed. Stable under recommended storage conditions. Hygroscopic. |
| 10.3 | Hazardous reactions | Hazardous polymerisation does not occur. |
| 10.4 | Conditions to avoid | Generation of gas from decomposition causes pressure in closed systems. Keep away from direct sunlight. Avoid high temperatures. Avoid temperatures exceeding the decomposition temperature. Avoid UV light. |
| 10.5 | Materials to avoid | Strong acids, Strong bases, Strong oxidising agents. |
| 10.6 | Hazardous decomposition products | Aldehydes, Alcohols, Ether, Organic acids. |

SECTION 11: TOXICOLOGICAL INFORMATION

| | | |
|-------|-------------------------------------|---|
| 11.1 | Toxicity Oral | LD50: > 20000 mg/kg (rat) This product can present a small hazard if large quantities are swallowed. |
| 11.2 | Inhalation | LC50: 6.15 mg/l (rat; 4 h; vapour) At ambient temperature the exposure to vapours is minimal due to a low volatility rate. Inhalation may cause irritation to the nose, throat, upper respiratory tract and lungs. No deaths occurred |
| 11.3 | Dermal | LD50: > 20000 mg/kg (rabbit) Prolonged skin contact is unlikely to result in absorption of harmful amounts. Skin irritation by prolonged exposure is unlikely. Repeated contact may cause flaking and softening of skin |
| 11.4 | Eyes | Slight irritation is possible. Direct contact with eyes may cause temporary irritation. Corneal injury is unlikely. |
| 11.5 | Sensitisation | Patch test on human volunteers did not demonstrate sensitisation properties. |
| 11.6 | CMR Carcinogenicity | Animal testing did not show any carcinogenic effects. Information given is based on data obtained from similar substances. |
| 11.7 | Mutagenicity | No data available. |
| 11.8 | Reproductive toxicity | No data available. |
| 11.9 | Specific Target Organ Toxicity | Single exposure no data available. Repeated exposure no data available. |
| 11.10 | Other toxic properties | Repeated dose toxicity. In rare cases, repeated excessive exposure to propylene glycol may cause central nervous system effects. Aspiration hazard: Due to its physical properties, the substance does probably not pose any aspiration hazard. |
| 11.11 | Other relevant toxicity information | Handle in accordance with good industrial hygiene and safety practice. |
| 11.12 | Experience with human exposure | Health injuries are not known or expected under normal use. |

| | | | | | | | | | |
|----------|-------|---------|-----|------|----------|--------|-----|------|----|
| Document | M-005 | Version | 1.1 | Date | 19/06/25 | Author | JWB | Page | 43 |
|----------|-------|---------|-----|------|----------|--------|-----|------|----|

| | | | | | |
|---|------------------------------------|--|------------|--|---|
| <p>Applied Thermal Control Ltd 39 Hayhill Industrial Estate Barrow upon Soar, Leicestershire LE12 8LD, United Kingdom</p> | | <p>SAFETY DATA SHEET HEXID A4 HEAT TRANSFER FLUID Conforming to Directive 1907/2006/EC</p> | |   | |
| Issue | 6.7 | Date | April 2025 | Page | 5 |
| SECTION 12: ECOLOGICAL INFORMATION | | | | | |
| 12.1 | Acute toxicity | <p>Fish - LC50: 40613 mg/l (Oncorhynchus mykiss; 96 h) (static test) Daphnia and other aquatic invertebrates - LC50: 18340 mg/l (Ceriodaphnia Dubia (water flea); 48 h) (static test) Algae - ErC50: 19000 mg/l (Pseudokirchneriella subcapitata (green algae); 96 h) (Growth inhibition) Bacteria - NOEC: > 20000 mg/l (Pseudomonas putida; 18 h) Chronic toxicity Aquatic invertebrates - NOEC: 13020 mg/l (Ceriodaphnia Dubia (water flea); 7 d) (semi-static test)</p> | | | |
| 12.2 | Persistence and degradability | <p>Biodegradability 81 % (anaerobic; Exposure Time: 28 d)(OECD 301 F) Readily biodegradable 96 % (anaerobic; Exposure Time: 64 d)(OECD 306.)</p> | | | |
| 12.3 | Bioaccumulative potential | BCF - 0.09 estimated Low bioaccumulative potential | | | |
| 12.4 | Mobility | Estimated Koc < 1, indicating very high soil mobility. | | | |
| 12.5 | PBT and vPvB assessment | Not a PBT or vPvB substance or mixture | | | |
| 12.6 | Other adverse affects | Do not flush into surface water or sanitary sewer system. Avoid subsoil penetration. This substance is not in Annex I of Regulation (EC) 2037/2000 on substances that deplete the ozone layer. | | | |
| SECTION 13: DISPOSAL CONSIDERATION | | | | | |
| 13.1 | Waste treatment methods | Disposal together with normal waste is not allowed. Special disposal required according to local regulations. Do not let product enter drains. Contact waste disposal services. | | | |
| 13.2 | Contaminated packaging | Empty contaminated packaging thoroughly. They can be recycled after thorough and proper cleaning. Packaging that cannot be cleaned are to be disposed of in the same manner as the product. | | | |
| 13.3 | European Waste Catalogue Number | No waste code according to the European Waste Catalogue can be assigned for this product, as the intended use dictates the assignment. The waste code is established in consultation with the regional waste disposer. | | | |
| SECTION 14: TRANSPORT INFORMATION | | | | | |
| Not dangerous goods for ADR, RID, IMDG, and IATA | | | | | |
| 14.1 | EEC Regulations | UNNO None. Class None. Packing Group None. Road & Rail Transport (ADR & RID) None. IMDG Not Applicable. ICOA None. | | | |
| 14.2 | Export commodity code | 39074000 Classification - Polycarbonates | | | |
| 14.3 | Weight and dimensions | 5Kg per 5 litre container. 19x14x29cm | | | |
| 14.4 | Manufactured in the United Kingdom | | | | |

User & Operation Manual

H-SERIES CHILLERS

| | | | | | | | | | |
|----------|-------|---------|-----|------|----------|--------|-----|------|----|
| Document | M-005 | Version | 1.1 | Date | 19/06/25 | Author | JWB | Page | 44 |
|----------|-------|---------|-----|------|----------|--------|-----|------|----|

Applied Thermal Control Ltd
39 Hayhill Industrial Estate
Barrow upon Soar, Leicestershire
LE12 8LD, United Kingdom

SAFETY DATA SHEET
HEXID A4 HEAT TRANSFER FLUID
Conforming to Directive 1907/2006/EC



Issue 6.7 Date April 2025 Page 6

SECTION 15: REGULATORY INFORMATION

| | |
|-----------------------------|---------------------------------------|
| 15.1 Classification | Not classified as hazardous to users. |
| 15.2 CAS No. | 57556 |
| 15.3 Risk or Safety phrases | None |
| 15.4 Labelling | None |

SECTION 14: OTHER INFORMATION

Key literature references and sources for data taken from supplier information and data from the "Database of registered substances" of the European Chemicals Agency (ECHA) were used to create this safety data sheet. Other information - The information provided in this Safety Data Sheet is correct to our knowledge at the date of its revision. The information given only describes the products with regard to safety arrangements and is not to be considered as a warranty or quality specification and does not constitute a legal relationship.

The information contained in this Safety Data Sheet relates only to the specific material designated and may not be valid for such material used in combination with any other material or in any process, unless specified in the text.



| | | | | | | | | | |
|----------|-------|---------|-----|------|----------|--------|-----|------|----|
| Document | M-005 | Version | 1.1 | Date | 19/06/25 | Author | JWB | Page | 45 |
|----------|-------|---------|-----|------|----------|--------|-----|------|----|

10.3 HEXID A6 SAFETY DATA SHEET

| | | | | | |
|---|--|--|------------|---|---|
| Applied Thermal Control Ltd 39 Hayhill Industrial Estate Barrow upon Soar, Leicestershire LE12 8LD, United Kingdom | | SAFETY DATA SHEET HEXID A6 HEAT TRANSFER FLUID Conforming to Directive 1907/2006/EC | |  SDIGROUP | |
| Issue | 6.7 | Date | April 2025 | Page | 1 |
| SECTION 1: IDENTIFICATION OF THE SUBSTANCE/MIXTURE AND OF THE COMPANY/UNDERTAKING | | | | | |
| 1.1 | Product Name | Hexid A4 | | | |
| 1.2 | Intended/Recommended Use | Heat Transfer Fluid | | | |
| 1.3 | Manufacturer | Applied Thermal Control Limited 39 Hayhill Industrial Estate, Barrow upon Soar, Leicestershire, LE12 8LD, United Kingdom. www.app-therm.com | | | |
| 1.4 | Emergency Telephone Number | +44(0)1530 839998 | | | |
| 1.5 | Email | sales@app-therm.com | | | |
| SECTION 2: HAZARDS IDENTIFICATION | | | | | |
| 2.1 | Classification of the substance or mixture | The product is not classified as dangerous according to Regulation (EC) No. 1272/2008. This mixture is not classified as dangerous according to Directive 1999/45/EC. This mixture has no classification under CLP | | | |
| 2.2 | Label elements | Label elements: This product has no label elements Signal Word: No signal word. Hazard statements: No known significant effects or critical hazards. Precautionary statements: Prevention, Response, Storage or Disposal: Not applicable. | | | |
| 2.3 | Other hazards | PBT: This product is not identified as a PBT/vPvB substance. | | | |
| SECTION 3: COMPOSITION/INFORMATION ON INGREDIENTS | | | | | |
| 3.1 | Chemical Nature | Water (CAS 7732-18-5), not classified. Propylene glycol (CAS 57-55-6) (REACH 01-2119456809-23) (EINECS 200-338-0) not classified. Fluorescein (trace) and biocide (trace) not classified. | | | |
| 3.2 | Food Grade | Food Grade | | | |
| SECTION 4: FIRST AID MEASURES | | | | | |
| 4.1 | Eye Contact | No special precautions required. Treat symptomatically. Rinse thoroughly with plenty of water, also under the eyelids. Remove contact lenses after a few minutes and continue rinsing. If symptoms persist, call a physician. | | | |
| 4.2 | Skin Contact | Wash off immediately with plenty of water. If skin irritation persists, call a physician. | | | |
| 4.3 | Inhalation | Remove to fresh air. If symptoms persist, call a physician. | | | |
| 4.4 | Ingestion | Rinse mouth with water. Never give anything by mouth to an unconscious person. If symptoms persist, call a physician. | | | |



| | | | | | | | | | |
|----------|-------|---------|-----|------|----------|--------|-----|------|----|
| Document | M-005 | Version | 1.1 | Date | 19/06/25 | Author | JWB | Page | 46 |
|----------|-------|---------|-----|------|----------|--------|-----|------|----|

| | | | | | |
|---|---------------------------------------|---|------------|---|---|
| <p>Applied Thermal Control Ltd 39 Hayhill Industrial Estate Barrow upon Soar, Leicestershire LE12 8LD, United Kingdom</p> | | <p>SAFETY DATA SHEET HEXID A6 HEAT TRANSFER FLUID Conforming to Directive 1907/2006/EC</p> | |  | |
| Issue | 6.7 | Date | April 2025 | Page | 2 |
| SECTION 5: FIREFIGHTING MEASURES | | | | | |
| 5.1 | Extinguishing media | Use extinguishing measures that are appropriate to local circumstances and the surrounding environment. Water spray, foam, dry powder or CO2. Alcohol-resistant foam | | | |
| 5.2 | Unsuitable extinguishing Media | High volume water jet. Do not use a solid water stream as it may scatter and spread fire. | | | |
| 5.3 | Specific hazards during firefighting | In fire conditions, toxic decomposition products may be formed (see also section 10). In combustion, emits fumes, smoke, carbon dioxide (CO2) and carbon monoxide (CO). Heating will cause a pressure rise - with severe risk of bursting and explosion, Violent steam generation or eruption may occur upon application of direct water to hot liquids. | | | |
| 5.4 | Advice for firefighters | In the event of fire, wear self-contained breathing apparatus. Wear personal protective equipment. Promptly isolate the scene by removing all persons from the vicinity of the incident if there is a fire. Keep containers cool by spraying with water if exposed to fire. Collect contaminated fire extinguishing water separately. This must not be discharged into drains. Burning fluids may be extinguished by dilution with water. | | | |
| SECTION 6: ACCIDENTAL RELEASE MEASURES | | | | | |
| 6.1 | Personal precautions | Use personal protective equipment. Avoid contact with skin and eyes. Keep unnecessary and unprotected personnel from entering the area. | | | |
| 6.2 | Precaution to protect the environment | Do not flush into surface water or sanitary sewer system. Avoid subsoil penetration. | | | |
| 6.3 | Clean-up procedures | Contain the spillage, soak up with non-combustible absorbent material, (e.g. sand, earth, diatomaceous earth, vermiculite) and transfer to a container for disposal according to local/national regulations (see section 13). Keep in suitable, closed containers for disposal. Dike the area of spill to prevent spreading and pump liquid to salvage tank. Treat recovered material as described in section 13 Disposal considerations. | | | |
| SECTION 7: HANDLING AND STORAGE | | | | | |
| 7.1 | Precautions for safe handling | Keep container tightly closed. Handle in accordance with good industrial hygiene and safety practice. Spills of these organic materials on hot fibrous insulations may lead to lowering of the auto-ignition temperatures possibly resulting in spontaneous combustion. | | | |
| 7.2 | Conditions for safe storage | Keep only in the original container. | | | |
| SECTION 8: EXPOSURE CONTROLS/PERSONAL PROTECTION | | | | | |

User & Operation Manual

H-SERIES CHILLERS

| | | | | | | | | | |
|----------|-------|---------|-----|------|----------|--------|-----|------|----|
| Document | M-005 | Version | 1.1 | Date | 19/06/25 | Author | JWB | Page | 47 |
|----------|-------|---------|-----|------|----------|--------|-----|------|----|

| | | | | | |
|--|---|---|------------|--|---|
| Applied Thermal Control Ltd 39 Hayhill Industrial Estate Barrow upon Soar, Leicestershire LE12 8LD, United Kingdom | | SAFETY DATA SHEET HEXID A6 HEAT TRANSFER FLUID Conforming to Directive 1907/2006/EC | |   | |
| Issue | 6.7 | Date | April 2025 | Page | 3 |
| 8.1 Control Parameters | Component: Propane-1,2-diol CAS-No. 57-55-6 Other Occupational Exposure Limit Values EH40 WEL, Time Weighted Average (TWA): Total vapour and particulates.150 ppm, 474 mg/m ³ EH40 WEL, Time Weighted Average (TWA): Particulate.10 mg/m ³ ELV (IE), Time Weighted Average (TWA): Total vapour and particulates.150 ppm, 470 mg/m ³ ELV (IE), Time Weighted Average (TWA): Particulate.10 mg/m ³ | | | | |
| 8.2 Exposure controls/Appropriate engineering controls | Local exhaust. If this product contains ingredients with exposure limits, use process enclosures, local exhaust ventilation or other engineering controls to keep worker exposure below any recommended or statutory limits. | | | | |
| Personal protective equipment | Respiratory protection: Suitable respiratory protective device Combination filter: A-P2 Filter Type: Combined particulates and organic vapour type Hand protection: Category short time exposure - Break through time> 10 min Protective index: Class 1 When prolonged exposure is expected: Break through time> 120 min Protective index: Class 4 Observe the information of the glove manufacturers on permeability. Protective gloves should be chosen according to Workplace Safety Assessment. Gloves recommended according to EN 374 (protection against chemicals). Material: Chemical resistant gloves made of butyl rubber or nitrile rubber category III according to EN 374. | | | | |
| SECTION 9: PHYSICAL AND CHEMICAL PROPERTIES | | | | | |
| 9.1 Appearance at 20°C | Fluorescent green clear liquid | | | | |
| 9.2 Odour | Almost odourless | | | | |
| 9.3 Flash Point | Boils without flashing | | | | |
| 9.4 Ignition Temperature | Not available | | | | |
| 9.5 Flammability Limit | Not available | | | | |
| 9.6 Oxidizing Properties | Not available | | | | |
| 9.7 Auto flammability | 450°C | | | | |
| 9.8 Density at 25°C | ~1.036g/cm ³ | | | | |
| 9.9 pH (as is) | 9 | | | | |
| 9.10 Boiling point | 102°C | | | | |
| 9.11 Solubility in water | Miscible | | | | |
| 9.12 Freezing point | -21°C | | | | |
| 9.13 Specific Heat Capacity | 3.78kJ/kg °K | | | | |
| 9.14 Viscosity, Kinetic, at 25°C | 3.51mPas | | | | |



| | | | | | | | | | |
|----------|-------|---------|-----|------|----------|--------|-----|------|----|
| Document | M-005 | Version | 1.1 | Date | 19/06/25 | Author | JWB | Page | 48 |
|----------|-------|---------|-----|------|----------|--------|-----|------|----|

Applied Thermal Control Ltd
39 Hayhill Industrial Estate
Barrow upon Soar, Leicestershire
LE12 8LD, United Kingdom

SAFETY DATA SHEET HEXID A6 HEAT TRANSFER FLUID

Conforming to Directive 1907/2006/EC



| | | | | | |
|-------|-----|------|------------|------|---|
| Issue | 6.7 | Date | April 2025 | Page | 4 |
|-------|-----|------|------------|------|---|

SECTION 10: STABILITY AND REACTIVITY

| | | |
|------|----------------------------------|--|
| 10.1 | Reactivity | Stable under recommended storage conditions. No dangerous reaction known under conditions of normal use. |
| 10.2 | Chemical stability | No decomposition if stored and applied as directed. Stable under recommended storage conditions. Hygroscopic. |
| 10.3 | Hazardous reactions | Hazardous polymerisation does not occur. |
| 10.4 | Conditions to avoid | Generation of gas from decomposition causes pressure in closed systems. Keep away from direct sunlight. Avoid high temperatures. Avoid temperatures exceeding the decomposition temperature. Avoid UV light. |
| 10.5 | Materials to avoid | Strong acids, Strong bases, Strong oxidising agents. |
| 10.6 | Hazardous decomposition products | Aldehydes, Alcohols, Ether, Organic acids. |

SECTION 11: TOXICOLOGICAL INFORMATION

| | | |
|-------|-------------------------------------|---|
| 11.1 | Toxicity Oral | LD50: > 20000 mg/kg (rat) This product can present a small hazard if large quantities are swallowed. |
| 11.2 | Inhalation | LC50: 6.15 mg/l (rat; 4 h; vapour) At ambient temperature the exposure to vapours is minimal due to a low volatility rate. Inhalation may cause irritation to the nose, throat, upper respiratory tract and lungs. No deaths occurred |
| 11.3 | Dermal | LD50: > 20000 mg/kg (rabbit) Prolonged skin contact is unlikely to result in absorption of harmful amounts. Skin irritation by prolonged exposure is unlikely. Repeated contact may cause flaking and softening of skin |
| 11.4 | Eyes | Slight irritation is possible. Direct contact with eyes may cause temporary irritation. Corneal injury is unlikely. |
| 11.5 | Sensitisation | Patch test on human volunteers did not demonstrate sensitisation properties. |
| 11.6 | CMR Carcinogenicity | Animal testing did not show any carcinogenic effects. Information given is based on data obtained from similar substances. |
| 11.7 | Mutagenicity | No data available. |
| 11.8 | Reproductive toxicity | No data available. |
| 11.9 | Specific Target Organ Toxicity | Single exposure no data available. Repeated exposure no data available. |
| 11.10 | Other toxic properties | Repeated dose toxicity. In rare cases, repeated excessive exposure to propylene glycol may cause central nervous system effects. Aspiration hazard: Due to its physical properties, the substance does probably not pose any aspiration hazard. |
| 11.11 | Other relevant toxicity information | Handle in accordance with good industrial hygiene and safety practice. |
| 11.12 | Experience with human exposure | Health injuries are not known or expected under normal use. |

| | | | | | | | | | |
|----------|-------|---------|-----|------|----------|--------|-----|------|----|
| Document | M-005 | Version | 1.1 | Date | 19/06/25 | Author | JWB | Page | 49 |
|----------|-------|---------|-----|------|----------|--------|-----|------|----|

Applied Thermal Control Ltd
39 Hayhill Industrial Estate
Barrow upon Soar, Leicestershire
LE12 8LD, United Kingdom

SAFETY DATA SHEET HEXID A6 HEAT TRANSFER FLUID

Conforming to Directive 1907/2006/EC



| | | | | | |
|-------|-----|------|------------|------|---|
| Issue | 6.7 | Date | April 2025 | Page | 5 |
|-------|-----|------|------------|------|---|

SECTION 12: ECOLOGICAL INFORMATION

| | | |
|------|-------------------------------|--|
| 12.1 | Acute toxicity | Fish - LC50: 40613 mg/l (Oncorhynchus mykiss; 96 h) (static test) Daphnia and other aquatic invertebrates - LC50: 18340 mg/l (Ceriodaphnia Dubia (water flea); 48 h) (static test) Algae - ErC50: 19000 mg/l (Pseudokirchneriella subcapitata (green algae); 96 h) (Growth inhibition) Bacteria - NOEC: > 20000 mg/l (Pseudomonas putida; 18 h) Chronic toxicity Aquatic invertebrates - NOEC: 13020 mg/l (Ceriodaphnia Dubia (water flea); 7 d) (semi-static test) |
| 12.2 | Persistence and degradability | Biodegradability 81 % (anaerobic; Exposure Time: 28 d)(OECD 301 F) Readily biodegradable 96 % (anaerobic; Exposure Time: 64 d)(OECD 306.) |
| 12.3 | Bioaccumulative potential | BCF - 0.09 estimated Low bioaccumulative potential |
| 12.4 | Mobility | Estimated Koc < 1, indicating very high soil mobility. |
| 12.5 | PBT and vPvB assessment | Not a PBT or vPvB substance or mixture |
| 12.6 | Other adverse affects | Do not flush into surface water or sanitary sewer system. Avoid subsoil penetration. This substance is not in Annex I of Regulation (EC) 2037/2000 on substances that deplete the ozone layer. |



SECTION 13: DISPOSAL CONSIDERATION

| | | |
|------|---------------------------------|--|
| 13.1 | Waste treatment methods | Disposal together with normal waste is not allowed. Special disposal required according to local regulations. Do not let product enter drains. Contact waste disposal services. |
| 13.2 | Contaminated packaging | Empty contaminated packaging thoroughly. They can be recycled after thorough and proper cleaning. Packaging that cannot be cleaned are to be disposed of in the same manner as the product. |
| 13.3 | European Waste Catalogue Number | No waste code according to the European Waste Catalogue can be assigned for this product, as the intended use dictates the assignment. The waste code is established in consultation with the regional waste disposer. |

SECTION 14: TRANSPORT INFORMATION

| | | |
|--|------------------------------------|--|
| Not dangerous goods for ADR, RID, IMDG, and IATA | | |
| 14.1 | EEC Regulations | UNNO None. Class None. Packing Group None. Road & Rail Transport (ADR & RID) None. IMDG Not Applicable. ICOA None. |
| 14.2 | Export commodity code | 39074000 Classification - Polycarbonates |
| 14.3 | Weight and dimensions | 5Kg per 5 litre container. 19x14x29cm |
| 14.4 | Manufactured in the United Kingdom | |

| | | | | | | | | | |
|----------|-------|---------|-----|------|----------|--------|-----|------|----|
| Document | M-005 | Version | 1.1 | Date | 19/06/25 | Author | JWB | Page | 50 |
|----------|-------|---------|-----|------|----------|--------|-----|------|----|

| | | | | | |
|--|---|--|------------|-------------|---|
| Applied Thermal Control Ltd 39 Hayhill Industrial Estate Barrow upon Soar, Leicestershire LE12 8LD, United Kingdom | SAFETY DATA SHEET HEXID A6 HEAT TRANSFER FLUID Conforming to Directive 1907/2006/EC |   | | | |
| Issue | 6.7 | Date | April 2025 | Page | 6 |
| <hr/> SECTION 15: REGULATORY INFORMATION <hr/> | | | | | |
| 15.1 Classification | <u>Not classified as hazardous to users.</u> | | | | |
| 15.2 CAS No. | <u>57556</u> | | | | |
| 15.3 Risk or Safety phrases | <u>None</u> | | | | |
| 15.4 Labelling | <u>None</u> | | | | |
| <hr/> SECTION 14: OTHER INFORMATION <hr/> | | | | | |
| <p>Key literature references and sources for data taken from supplier information and data from the "Database of registered substances" of the European Chemicals Agency (ECHA) were used to create this safety data sheet.</p> <p>Other information - The information provided in this Safety Data Sheet is correct to our knowledge at the date of its revision. The information given only describes the products with regard to safety arrangements and is not to be considered as a warranty or quality specification and does not constitute a legal relationship.</p> <p>The information contained in this Safety Data Sheet relates only to the specific material designated and may not be valid for such material used in combination with any other material or in any process, unless specified in the text.</p> | | | | | |

| | | | | | | | | | |
|----------|-------|---------|-----|------|----------|--------|-----|------|----|
| Document | M-005 | Version | 1.1 | Date | 19/06/25 | Author | JWB | Page | 51 |
|----------|-------|---------|-----|------|----------|--------|-----|------|----|

10.4 COOLFLOW EG SAFETY DATA SHEET



Safety Data Sheet

Applied Thermal Control Ltd
39 Hayhill Industrial Estate
Barrow Upon Soar
Leicestershire, LE12 8LD

Tel: +44(0) 1530 839998

Temperature Control for Industrial, Medical & Scientific Applications

sales@app-therm.com
www.app-therm.com

Section 1: Identification of the substance/ mixture and of the company/ undertaking

1.1 Product identifier

Product Name CoolFlow EG

1.2 Relevant identified uses of the substance or mixture and uses advised against

Identified uses Industrial grade secondary refrigerant with antifreeze and inhibitor functions designed for use in process cooling, refrigeration and HVAC systems.

Uses advised against This product is not recommended for any industrial, professional or consumer use other than the identified uses above.

1.3 Details of the supplier of the Safety Data Sheet

Supplier Applied Thermal Control Ltd
39 Hayhill Industrial Estate
Barrow Upon Soar
Leicestershire
LE12 8LD
+44 (0) 01530 839998
sales@app-therm.com

1.4 Opening Hours Monday-Thursday - 08:00 - 17:00 Friday - 08:00 - 14:00

Section 2: Hazards identification

2.1 Classification of the substance or mixture

Classification - Regulation (EC) No. 1272/2008 (CLP)

Physical and chemical hazards Not classified as a physical or chemical hazard
Human health Acute Tox. 4 - H302, STOT RE 2 - H373
Environment Not classified as an environmental hazard

2.2 Label elements

EC No. N/A

Labelling - Regulation (EC) No. 1272/2008 (CLP)

Pictograms



Signal Word - Warning

SD-015-2

CoolFlow EG Antifreeze

User & Operation Manual

H-SERIES CHILLERS

| | | | | | | | | | |
|----------|-------|---------|-----|------|----------|--------|-----|------|----|
| Document | M-005 | Version | 1.1 | Date | 19/06/25 | Author | JWB | Page | 52 |
|----------|-------|---------|-----|------|----------|--------|-----|------|----|



Safety Data Sheet

Applied Thermal Control Ltd
39 Hayhill Industrial Estate
Barrow Upon Soar
Leicestershire, LE12 8LD

Tel: +44(0) 1530 839998

Temperature Control for Industrial, Medical & Scientific Applications

sales@app-therm.com
www.app-therm.com

Hazard statements

H302 - Harmful if swallowed

H373 - May cause damage to organs - Kidneys - through prolonged or repeated exposure if swallowed.

Precautionary statements

P260 - Do not breathe dust/fumes/gas/mist/vapours/spray

P264 - Wash hands thoroughly after handling

P270 - Do not eat, drink or smoke when using this product

P301+P312 - IF SWALLOWED: Call a POISON CENTRE or doctor/physician if you feel unwell

P301+P330+P331 - IF SWALLOWED: Rinse mouth. Do NOT induce vomiting.

2.3 Other hazards

This product does not meet the PBT/vPvB criteria of REACH, annex XIII.

Section 3: Composition/information on ingredients

3.2 Mixtures

Component - Monoethylene glycol (ethane-1, 2-diol)

Concentration 80-95%
EC No. 203-473-3
CAS No. 107-21-1
Reach registration No. 01-2119456816-28

Classification - Regulation (EC) No. 1272/2008 (CLP)

Acute Tox. 4 - H302
STOT RE 2 - H373

Component - Ethanol

Concentration 1-5%
EC No. 200-578-6
CAS No. 64-17-5
Reach registration No. 01-211945719-43

Classification - Regulation (EC) No. 1272/2008 (CLP)

Flam. Liq. 2 - H225
Eye Irrit. 2 - H319

Component - Sodium nitrite

Concentration <0.25%
EC No. 231-555-9
CAS No. 7632-00-0
Reach registration No. 01-2119471836-27

Classification - Regulation (EC) No. 1272/2008 (CLP)

Ox. Sol. 3 - H272
Acute Tox. 3 - H301
Eye Irrit. 2 - H319
Aquatic Acute 1 - H400

SD-015-2

CoolFlow EG Antifreeze



User & Operation Manual

H-SERIES CHILLERS

| | | | | | | | | | |
|----------|-------|---------|-----|------|----------|--------|-----|------|----|
| Document | M-005 | Version | 1.1 | Date | 19/06/25 | Author | JWB | Page | 53 |
|----------|-------|---------|-----|------|----------|--------|-----|------|----|



Safety Data Sheet

Applied Thermal Control Ltd
39 Hayhill Industrial Estate
Barrow Upon Soar
Leicestershire, LE12 8LD

Tel: +44(0) 1530 839998

Temperature Control for Industrial, Medical & Scientific Applications

sales@app-therm.com
www.app-therm.com

Section 4: First aid procedures

4.1 Description of first aid procedures

| | |
|---------------------|---|
| General Information | When safe to do so remove the victim from the source of exposure giving consideration as to whether this may cause further discomfort to the victim. |
| Inhalation | Move the affected person to fresh air at once. Keep warm in a position comfortable for breathing. If breathing becomes difficult, properly trained personnel may assist the victim by supplying oxygen to ease breathing. Get medical attention if any discomfort continues. |
| Ingestion | Do NOT induce vomiting and seek medical attention immediately. Move victim to fresh air and keep warm and at rest in a position comfortable for breathing. Give victim approximately 250 mL of water however, do not give victim anything to drink if not fully conscious. If medical advice is delayed and an adult has consumed several ounces of this chemical, give approximately 100 mL of hard liquor (for children give 2 mL per kilogram of body weight). |
| Skin Contact | Remove contaminated clothing immediately and wash skin with soap and water. Get medical attention if any discomfort continues. |
| Eye Contact | Rinse immediately with plenty of water. Remove any contact lenses and open eyelids wide apart. Continue to rinse for at least 15 minutes. Get medical attention if any discomfort continues. |

4.2 Most important symptoms and effects, both acute and delayed

| | |
|---------------------|---|
| General Information | The following symptoms are listed in case of exposure to the 100% neat product. |
| Inhalation | Inhalation of vapours may cause mild irritation of the upper respiratory tract. |
| Ingestion | Initial symptoms may include an upset stomach, nausea, vomiting and diarrhoea. Symptoms may progress to hyperventilation, metabolic acidosis, cardiovascular dysfunction and acute kidney failure depending on the extent of poisoning. |
| Skin Contact | Prolonged and repeated contact may cause mild irritation of the skin. |
| Eye Contact | Direct eye contact may cause reddening of the eyes. |

4.3 Indication of immediate medical needs or special treatment

If several ounces (> 50 mL) of this product have been ingested, early administration of ethanol may help to counteract the toxic side effects such as metabolic acidosis, cardiovascular dysfunction and in severe cases kidney failure. Consider haemodialysis or peritoneal dialysis and thiamine 100 mg plus pyridoxine 50 mg intravenously every 6 hours. If ethanol is used a therapeutically effective blood concentration in the range of 100-150 mg/dL may be achieved by a rapid loading dose followed by a continuous intravenous fusion.

Respiratory symptoms such as pulmonary edema, may be delayed. Victims receiving significant exposure should be kept under observation for 24-48 hours for signs of respiratory distress. In the case of severe poisoning, respiratory support with mechanical ventilation and oxygenation of the patient.

Notes for the doctor

No specific recommendations in addition to the suggestions in Sections 4.1 and 4.3. Treat symptomatically.

SD-015-2

CoolFlow EG Antifreeze



User & Operation Manual

H-SERIES CHILLERS

| | | | | | | | | | |
|----------|-------|---------|-----|------|----------|--------|-----|------|----|
| Document | M-005 | Version | 1.1 | Date | 19/06/25 | Author | JWB | Page | 54 |
|----------|-------|---------|-----|------|----------|--------|-----|------|----|



Safety Data Sheet

Applied Thermal Control Ltd
39 Hayhill Industrial Estate
Barrow Upon Soar
Leicestershire, LE12 8LD

Tel: +44(0) 1530 83998

Temperature Control for Industrial, Medical & Scientific Applications

sales@app-therm.com
www.app-therm.com

Section 5: Firefighting measures

5.1 Extinguishing media

Extinguish with alcohol-resistant foam, carbon dioxide (CO₂), dry chemicals, sand and dolomite or water fog.

5.2 Special hazards arising from the substance or mixture

Specific Hazards When heated and in the case of a fire, harmful vapours/gases (such as carbon monoxide and carbon dioxide) may be formed.

Unusual fire and explosion hazards Exposure to extreme heat may cause product containers to explode.

5.3 Advice for firefighting

Protective actions during firefighting Move containers away from fire area if this can be done without risk. Keep people away, isolate the fire and deny unnecessary entry. Use water fog to keep fire-exposed containers cool and disperse vapours. Runoff water should be prevented from entering sewers and watercourses.

Specialist protective equipment for Wear positive-pressure self-contained breathing apparatus (SCBA) and full Fire fighters protective clothing.

Section 6: Procedure for unwanted emissions

6.1 Personal precautions, protective equipment and emergency procedures

Personal precautions

Avoid flames, sparks, heat and smoking.
In the case of inadequate ventilation, use respiratory protection.

Protective Equipment

Wear protective clothing as described in Section 8 of this Safety Data Sheet.

Emergency Procedures

Stop leak/release if possible to do so without risk.
Extinguish all ignition sources if safe to do so.
Warn everybody of potential danger and evacuate if necessary.

6.2 Environmental precautions

Do not discharge into drains, water courses or onto the ground.
Spillages or uncontrolled discharges into watercourses must be reported immediately to the Environmental Agency or other appropriate regulatory body.

6.3 Methods and materials for containment and clean up

Absorb spillage with inert, damp, non-combustible material, then flush the contaminated area with water.
Containers with collected spillage should be appropriately labelled with the correct contents and hazard labels.
Collect and place in suitable waste disposal containers and seal securely. For waste disposal, see Section 13.

6.4 Reference to other sections

Wear protective clothing as described in Section 8 of this Safety Data Sheet.
Collect and dispose of spillage as indicated in Section 13.

SD-015-2

CoolFlow EG Antifreeze



Applied Thermal Control Ltd - service@app-therm.com - +44 (0) 1530 83 99 98
39 Hayhill Industrial Estate, Barrow-upon-Soar, Loughborough, LE12 8LD, United Kingdom



User & Operation Manual

H-SERIES CHILLERS

| | | | | | | | | | |
|----------|-------|---------|-----|------|----------|--------|-----|------|----|
| Document | M-005 | Version | 1.1 | Date | 19/06/25 | Author | JWB | Page | 55 |
|----------|-------|---------|-----|------|----------|--------|-----|------|----|



Safety Data Sheet

Applied Thermal Control Ltd
39 Hayhill Industrial Estate
Barrow Upon Soar
Leicestershire, LE12 8LD

Tel: +44(0) 1530 839998

Temperature Control for Industrial, Medical & Scientific Applications

sales@app-therm.com
www.app-therm.com

Section 7: Handling and storage

7.1 Precautions for safe handling

Avoid spilling and contact with the skin and the eyes as well as direct inhalation of sprays and mists.
Provide good ventilation.
Do not eat, drink or smoke in work areas and wash hands after handling this product.

7.2 Conditions for safe storage including any compatibilities

Store in tightly-closed, original containers.
Keep separate from food, feedstuffs, fertilisers and other sensitive material.
Do not store near heat sources or expose to high temperatures.
Keep away from heat, sparks and open flame.

7.3 Specific end use(es)

The identified uses for this product are detailed in Section 1.2.

Section 8: Exposure controls / Personal protection

8.1 Control parameters

| Name | STD | TWA-8 Hrs | STEL-15 Min |
|--|-----|----------------------|-----------------------|
| Monoethylene glycol (ethane-1, 2-diol) | WEL | 52 mg/m ³ | 104 mg/m ³ |

DNEL

Industry, Inhalation - Long term local effects: 35mg/m³
Industry, Dermal - Long term systemic effects: 106mg/m³
Consumer, Inhalation - Long term local effects: 7mg/m³
Consumer, Dermal - Long term systemic effects: 7mg/m³

PNEC

Fresh water: 10 mg/L
Marine water: 1mg/L
STP: 199.5 mg/L
Sediment fresh water: 20.9 mg/kg
Soil: 1.53 mg/kg

| Name | STD | TWA-8 Hrs | STEL-15 Min |
|---------|-----|------------------------|---------------|
| Ethanol | WEL | 1920 mg/m ³ | Not available |

DNEL

Industry, Inhalation - Short term local effects: 1900 mg/m³
Industry, Dermal - Long term systemic effects: 343 mg/kg/day
Industry, Inhalation - Long term systemic effects: 950 mg/m³
Consumer, Inhalation - Short term local effects: 950 mg/m³

Consumer, Dermal - Long term systemic effects: 206 mg/kg/day
Consumer, Inhalation - Long term systemic effects: 114 mg/m³
Consumer, Oral - Long term systemic effects: 87 mg/kg/day

PNEC

Fresh water: 0.96 mg/L
Marine water: 0.79 mg/L

SD-015-2

CoolFlow EG Antifreeze



User & Operation Manual

H-SERIES CHILLERS

| | | | | | | | | | |
|----------|-------|---------|-----|------|----------|--------|-----|------|----|
| Document | M-005 | Version | 1.1 | Date | 19/06/25 | Author | JWB | Page | 56 |
|----------|-------|---------|-----|------|----------|--------|-----|------|----|



Safety Data Sheet

Applied Thermal Control Ltd
39 Hayhill Industrial Estate
Barrow Upon Soar
Leicestershire, LE12 8LD

Tel: +44(0) 1530 839998

Temperature Control for Industrial, Medical & Scientific Applications

sales@app-therm.com
www.app-therm.com

Intermittent release: 2.75 mg/L
STP: 580 mg/L
Sediment fresh water: 3.6 mg/kg
Sediment marine water: 2.9 mg/kg
Soil: 0.63 mg/kg

| Name | STD | TWA-8 Hrs | STEL-15 Min |
|----------------|-----|---------------|---------------|
| Sodium nitrite | WEL | Not available | Not available |

DNEL
Industry, Inhalation - Long term systemic effects: 2 mg/m³
Industry, Inhalation - Short term systemic effects: 2 mg/m³

PNEC
Fresh water: 0.0054 mg/L
Marine water: 0.00616 mg/L
Intermittent release: 0.0054 mg/L
Sediment (fresh water): 0.0195 mg/kg
Sediment (marine water): 0.0223 mg/kg
STP: 21 mg/L

8.2 Exposure controls



Technical procedures

| | |
|-----------------------|---|
| Engineering measures | Methods to prevent or control exposure are preferred. Provide adequate ventilation to minimise the risk of inhalation of sprays and mists. |
| Hygiene measures | Handle in accordance with good industrial hygiene and safety practices. Wash hands after handling this product and at the end of each work shift. Routinely wash work clothing and personal protective equipment to remove possible contaminants. |
| Respiratory equipment | Where risk assessment shows air-purifying respirators are appropriate use a full-face respirator with multi-purpose combination (US) or type ABEK (EN 14387) respirator cartridges as a backup to engineering controls. If the respirator is the sole means of protection, use a full-face supplied air respirator. Use respirators and components tested and approved under appropriate government standards such as NIOSH (US) or CEN (EU). |
| Hand protection | PVC/butyl rubber/neoprene gloves are recommended. |
| Eye protection | Wear approved chemical goggles or face shield. |
| Skin Protection | Wear rubber apron or protective clothing in case of contact. |
| Other Protection | Wear suitable protective clothing/footwear as protection against splashing or contamination. |

SD-015-2

CoolFlow EG Antifreeze



User & Operation Manual

H-SERIES CHILLERS

| | | | | | | | | | |
|----------|-------|---------|-----|------|----------|--------|-----|------|----|
| Document | M-005 | Version | 1.1 | Date | 19/06/25 | Author | JWB | Page | 57 |
|----------|-------|---------|-----|------|----------|--------|-----|------|----|



Safety Data Sheet

Applied Thermal Control Ltd
39 Hayhill Industrial Estate
Barrow Upon Soar
Leicestershire, LE12 8LD

Tel: +44(0) 1530 839998

Temperature Control for Industrial, Medical & Scientific Applications

sales@app-therm.com
www.app-therm.com

| | |
|---------------------------------|---|
| Thermal Hazards | No specific measures required. |
| Environmental Exposure Controls | Product not classified as an environmental hazard - no specific environmental exposure controls required. |

Section 9: Physical and chemical properties

9.1 Information on basic physical and chemical properties

| | |
|--|--|
| Appearance | Blue liquid |
| Odour | Non-pungent but characteristic aroma |
| Odour Threshold | Not applicable |
| pH | 7.5 - 10.5 depending on inhibitor formulation |
| Melting point / Pour point | -40°C |
| Initial boiling point | >180°C |
| Flash point | >64°C |
| Evaporation Rate | No test data available |
| Flammability | Product is not classified as flammable |
| Flammability / explosion limits | Upper limit: 13% Lower limit: 3% |
| Vapour pressure | No test data available |
| Vapour density (air = 1) | No test data available |
| Relative density of the mixture | 1.04 - 1.2 |
| Solubility | Soluble in water |
| Partition coefficient: n-octanol / water | No test data available |
| Auto-ignition temperature | >390°C |
| Decomposition temperature | No test data available |
| Viscosity | See product data sheet |
| Explosive properties | Not applicable - product is not classified as an explosive |
| Oxidising properties | Not applicable - product is not classified as an oxidising agent |

9.2 Other information

Not determined.

Section 10: Stability and reactivity

10.1 Reactivity

There are no known reactivity hazards associated with this product.

10.2 Chemical stability

Stable at normal ambient temperatures and when used as recommended.
Product is hygroscopic and will absorb water by contact with the moisture in the air.

10.3 Possibility of hazardous reactions

There are no known hazardous reactions associated with this product.

10.4 Conditions to avoid

Avoid temperatures >180°C for prolonged periods of time, flames and sources of ignition.

10.5 Incompatible materials

Strong acids, strong alkalis and strong oxidising agents.

10.6 Hazardous decomposition products

SD-015-2

CoolFlow EG Antifreeze



User & Operation Manual

H-SERIES CHILLERS

| | | | | | | | | | |
|----------|-------|---------|-----|------|----------|--------|-----|------|----|
| Document | M-005 | Version | 1.1 | Date | 19/06/25 | Author | JWB | Page | 58 |
|----------|-------|---------|-----|------|----------|--------|-----|------|----|



Safety Data Sheet

Applied Thermal Control Ltd
39 Hayhill Industrial Estate
Barrow Upon Soar
Leicestershire, LE12 8LD

Tel: +44(0) 1530 839998

Temperature Control for Industrial, Medical & Scientific Applications

sales@app-therm.com
www.app-therm.com

No known hazardous decomposition products. Potentially hazardous products released due to fire are listed in Section 5.2 of this Safety Data Sheet.

Section 11: Toxicological information

11.1 Information on toxicological effects

Acute toxicity

This product has not been tested as a whole for acute toxicity health effects. For this reason, the acute toxicity values for the main components of this mixture are listed below.

Acute toxicity values for monoethylene glycol:

LD50, oral, rat: 4700 mg/kg bw

LD50, dermal, rabbit: >10,600 mg/kg bw

LD50, dermal, mouse: >3500 mg/kg bw

LC50, inhalation (vapours), rat: >2.5 mg/L

Oral toxicity of monoethylene glycol is expected to be moderate in humans despite animal testing showing a lower degree of toxicity. The estimated lethal dose in humans of NEAT MONOETHYLENE GLYCOL is expected to be approximately 100mL.

Acute toxicity values for ethanol:

LD50, oral, rat: 10,470 mg/kg bw

LD50, dermal rabbit: 17,100 mg/kg bw

Skin corrosion/ irritation
Serious eye damage/ irritation

Skin irritation is not expected when this product is used/handled correctly.
Eye irritation is not expected when this product is used/handled correctly.

Respiratory/ skin sensitisation
Germ cell mutagenicity
Carcinogenicity
Reproductive toxicity

Product not classified as a skin/respiratory sensitiser.
Product is not expected to be mutagenic.
Product is not expected to be carcinogenic.
Product is not expected to damage the reproductive system or harm a developing fetus.

Evaluation of CMR properties
STOT-single exposure

No test data available.
No test data available.

STOT-repeated exposure
Aspiration hazard

No test data available.
No test data available.

General information

See Section 4.2 of this Safety Data Sheet.

Inhalation

Inhalation of vapours may cause mild irritation of the upper respiratory tract.

Ingestion

Initial symptoms may include an upset stomach, nausea, vomiting and diarrhoea. Symptoms may progress to hyperventilation, metabolic acidosis, cardiovascular dysfunction and acute kidney failure depending on the extent of poisoning.

Skin contact

Prolonged and repeated contact may cause mild irritation of the skin.

Eye contact

Direct eye contact may cause reddening of the eyes.

SD-015-2

CoolFlow EG Antifreeze



User & Operation Manual

H-SERIES CHILLERS

| | | | | | | | | | |
|----------|-------|---------|-----|------|----------|--------|-----|------|----|
| Document | M-005 | Version | 1.1 | Date | 19/06/25 | Author | JWB | Page | 59 |
|----------|-------|---------|-----|------|----------|--------|-----|------|----|



Safety Data Sheet

Applied Thermal Control Ltd
39 Hayhill Industrial Estate
Barrow Upon Soar
Leicestershire, LE12 8LD

Tel: +44(0) 1530 839998

Temperature Control for Industrial, Medical & Scientific Applications

sales@app-therm.com
www.app-therm.com

Section 12: Ecological information

Ecotoxicity

The product is not classified as hazardous to the environment.

12.1 Toxicity

LC50, 96 hours, fish: >100 mg/L - not classified as harmful to fish
EC50, 48 hours, daphnia magna: >100 mg/L - not classified as harmful to daphnia
EC50, 96 hours, aquatic plants: >100 mg/L - not classified as harmful to aquatic plants

12.2 Persistence and degradability

This product is readily biodegradable (90% over 10 days).

12.3 Bioaccumulative potential

Will not bio-accumulate.
Partition coefficient - not determined.

12.4 Mobility in soil

Product is mobile in soil as it is water soluble.

12.5 Results of PBT and vPvB assessment

This product does not meet the PBT/vPvB criteria of REACH, annex XIII.

12.6 Other adverse effects

Not determined.

Section 13: Advice on disposal

General information

Waste to be treated as controlled waste. Disposal to licensed waste disposal site in accordance with Local Waste Disposal Authority.

Disposal methods

Dispose of waste and residues in accordance with local authority and/or local sewage treatment plant requirements.

Section 14: Transport information

14.1 UN number

Product not hazardous for transport - no information required.

14.2 UN proper shipping name

Product not hazardous for transport - no information required

14.3 Transport hazard class(es)

Product not hazardous for transport - no information required.

Transport labels

Product not hazardous for transport - no information required.

14.4 Packing group

Product not hazardous for transport - no information required.

SD-015-2

CoolFlow EG Antifreeze



User & Operation Manual

H-SERIES CHILLERS

| | | | | | | | | | |
|----------|-------|---------|-----|------|----------|--------|-----|------|----|
| Document | M-005 | Version | 1.1 | Date | 19/06/25 | Author | JWB | Page | 60 |
|----------|-------|---------|-----|------|----------|--------|-----|------|----|



Safety Data Sheet

Applied Thermal Control Ltd
39 Hayhill Industrial Estate
Barrow Upon Soar
Leicestershire, LE12 8LD

Tel: +44(0) 1530 839998

Temperature Control for Industrial, Medical & Scientific Applications

sales@app-therm.com
www.app-therm.com

14.5 Environmental hazards

Product not classed as an environmentally hazardous substance or marine pollutant.

14.6 Special precautions for user

Product not hazardous for transport - no information required.

14.7 Transport in bulk according to Annex II of MARPOL73/78 and the IBC Code

Product not hazardous for transport - no information required.

Section 15: Regulatory information

15.1 Safety, health and environmental regulations / legislation for the substance or mixture

EU legislation

Regulation (EC) No 1907/2006 of the European Parliament and of the Council of 18 December 2006 concerning the Registration, Evaluation Authorisation and Restriction of Chemicals (REACH) (as amended). Regulation (EC) No 1272/2008 of the European Parliament and of the Council of 16 December 2008 on classification, labelling and packaging of substances and mixtures (as amended).

Guidance notes

CHIP for everyone HSG228. Approved Classification and Labelling Guide (Sixth edition) L131. Safety Data Sheets for substances and preparations.

15.2 Chemical safety assessment

No chemical safety assessment for this mixture has been carried out.

Section 16: Other information

Issued by Thermal Exchange Ltd
Revision Date 21/03/2018
Approved by Graham Wade
Revision Comments Review in line with CLP regulation

Hazard statements in full

The following hazard statements are the hazard statements 'in full' for the components of this mixture. They are not the hazard statements associated with the final classification of this product.

H302 - Harmful if swallowed
H373 - May cause damage to organs - Kidneys - through prolonged or repeated exposure if swallowed
H225 - Highly flammable liquid and vapour
H319 - Causes serious eye irritation
H272 - May intensify fire; oxidiser

H301 - Toxic if swallowed
H400 - Very toxic to aquatic life

Further classification and composition comments

No further classification or composition comments required.

SD-015-2

CoolFlow EG Antifreeze



User & Operation Manual

H-SERIES CHILLERS

| | | | | | | | | | |
|----------|-------|---------|-----|------|----------|--------|-----|------|----|
| Document | M-005 | Version | 1.1 | Date | 19/06/25 | Author | JWB | Page | 61 |
|----------|-------|---------|-----|------|----------|--------|-----|------|----|



Safety Data Sheet

Applied Thermal Control Ltd
39 Hayhill Industrial Estate
Barrow Upon Soar
Leicestershire, LE12 8LD

Tel: +44(0) 1530 839998

Temperature Control for Industrial, Medical & Scientific Applications

sales@app-therm.com
www.app-therm.com

(i) Indication of changes

Safety Data Sheet updated to comply with the new requirements as set out in Regulation (EC) No. 1272/2008 (CLP).

(ii) Abbreviations and acronyms

bw: bodyweight

CAS No: Chemical Abstracts Service number

CLP: Classification Labelling and Packaging Regulation

DNEL: Derived No-Effect Level

EC: European Commission

EC No: European Chemical number: EINECS, ELINCS or NLP

ECHA: European Chemicals Agency

EINECS: European Inventory of Existing Commercial Chemical Substances

ELINCS: European List of Notified Chemical Substances

LC50: Lethal Concentration, 50%

LD50: Median Lethal Dose

PBT: Persistent, Bioaccumulative & Toxic

PNEC: Predicted No Effect Concentration

REACH: Registration, Evaluation, Authorisation & restrictions of Chemicals

SDS: Safety Data Sheet

vPvB: Very Persistent and Very Bioaccumulative

WEL: Workplace Exposure Limit

(iii) Training advice

Product should only be handled by trained operators.

(iv) Additional information

The above information describes exclusively the safety requirements of the product and is based on our present-day knowledge. The information is intended to give advice about the safe handling of the product named in this Safety Data Sheet, for storage, processing, transport and disposal. The information cannot be transferred to other products. In the case of mixing the product with products or in the case of processing, the information on this Safety Data Sheet is not necessarily valid for the new made-up material.