



Applied Thermal Control Ltd
39 Hayhill Industrial Estate
Barrow-upon-Soar, Loughborough
LE12 8LD, United Kingdom
+44 (0) 1530 839 998
Service@thermalexchange.co.uk
Support@app-therm.com

Installation, Operation & Service Manual

M05

DOCUMENT DETAILS

Date	16/MAR/2023	Author(s)	MJH	Page	1 / 5	Revision	6
------	-------------	-----------	-----	------	-------	----------	---

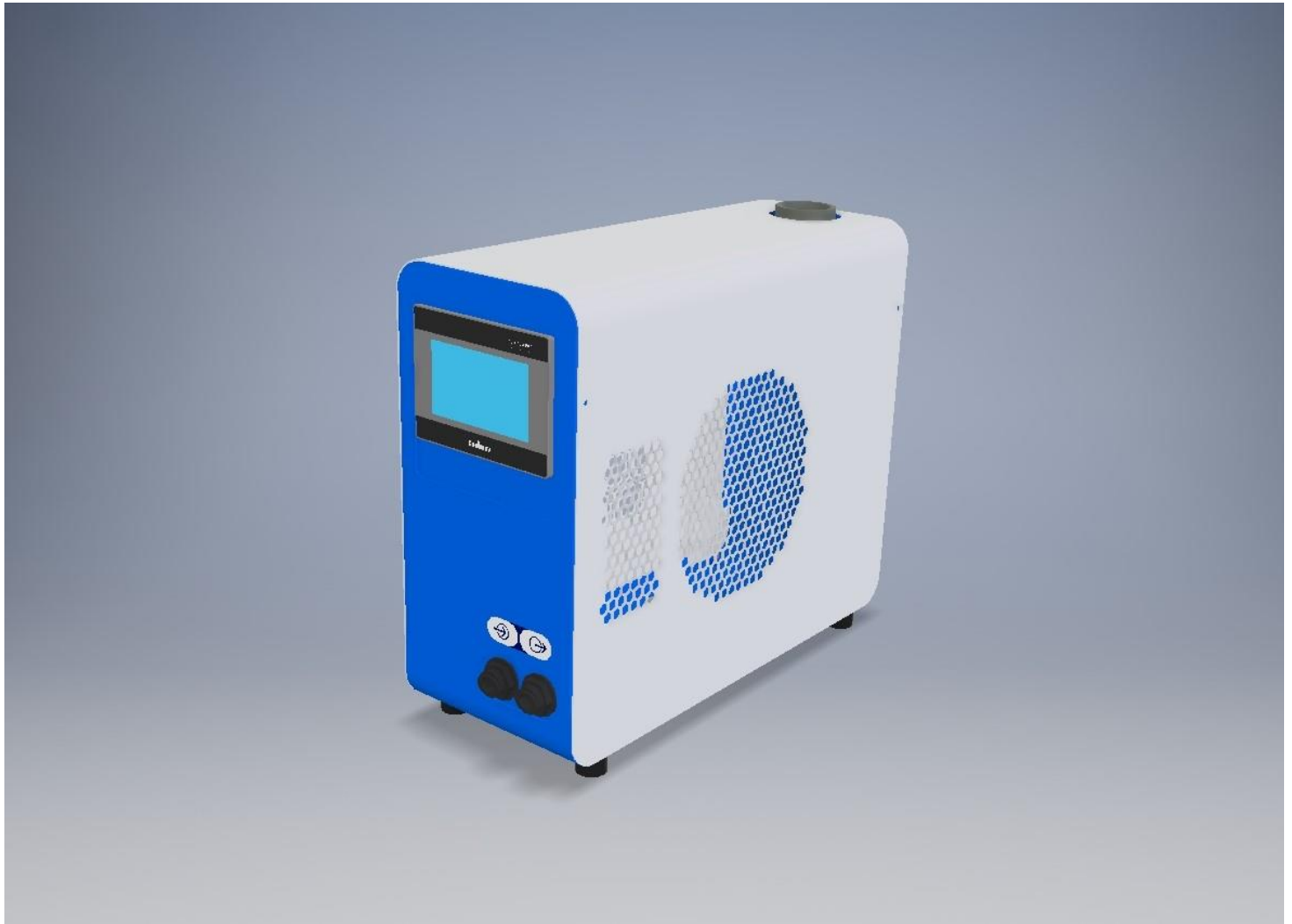



Applied Thermal Control Ltd
 39 Hayhill Industrial Estate
 Barrow-upon-Soar, Loughborough
 LE12 8LD, United Kingdom
 +44 (0) 1530 839 998
 Service@thermalexchange.co.uk
 Support@app-therm.com

Installation, Operation & Service Manual

M05

DOCUMENT DETAILS

Date	16/MAR/2023	Author(s)	MJH	Page	2 / 5	Revision	6
------	-------------	-----------	-----	------	-------	----------	---

CHANGE LOG

Date	Revision	Page ref	Change
5/DEC/2019	1	-	First release.
27/JAN/2020	2	Product Specification	Pump curve graph edited.
		Annex L	Inclusion of RS485 ModBUS Protocol guide
28/AUG/2020	3	Annex C	Correction to standard fittings supply
28/OCT/2020	4	Product Specification	Clarification of QR size
9/MAR/2022	5	Opening section	Updated product model name to M05
16/MAR/2023	6	Annex E, Annex L	Updated due to touchscreen modifications



Applied Thermal Control Ltd
 39 Hayhill Industrial Estate
 Barrow-upon-Soar, Loughborough
 LE12 8LD, United Kingdom
 +44 (0) 1530 839 998
 Service@thermalexchange.co.uk
 Support@app-therm.com

Installation, Operation & Service Manual

M05

DOCUMENT DETAILS

Date	16/MAR/2023	Author(s)	MJH	Page	3 / 5	Revision	6
------	-------------	-----------	-----	------	-------	----------	---

PRODUCT SPECIFICATIONS

Attribute	Unit	Value
Dimensions (W*D*H)	mm	180*435*380
	inch	7.1*17.1*15
Weight	kg	20
	lbs.	44.1
Heat transfer fluid volume	mL	650
	USGal	0.172
Cooling capacity (T _{ambient} +20°C / +68°F) (T _{setpoint} +20°C / +68°F)	W	500
	BTU/h	1706
	RT	0.142
Temp. adjustment	±°C	0.1
Settable temp. range	°C	+4 to +35
Optional temp. range	°C	-10 to +65
Power supply requirement	VAC	100-240
	Hz	50/60
	A	1@240VAC 2@115VAC
Sound pressure level	dBa	35-64
Controller screen size	inch	4.3" diagonal
Auto-diagnostic functions		PID, compressor and fan percentage utilization. Fridge system high pressure value. Compressor error states. Export system log via USB.
Fluid fittings (standard)		Pushfit 12mm
Fluid fittings (option)		Valved QR 9.5mm (3/8")
Low fluid level alarm		Visual, 3 level
Controller screen		Resistive type, glove-friendly, pen-friendly.
Tool-less access		No
Overtemperature protection		Hardware limited Software settable
Compressor overload protection		Via PCB function
Overcurrent protection		Fused, 2* T6.3A H250V
Rated duty cycle		Continuous
Compatible heat transfer fluids		DI water, propylene glycol mixes, Hexid A4 & A6

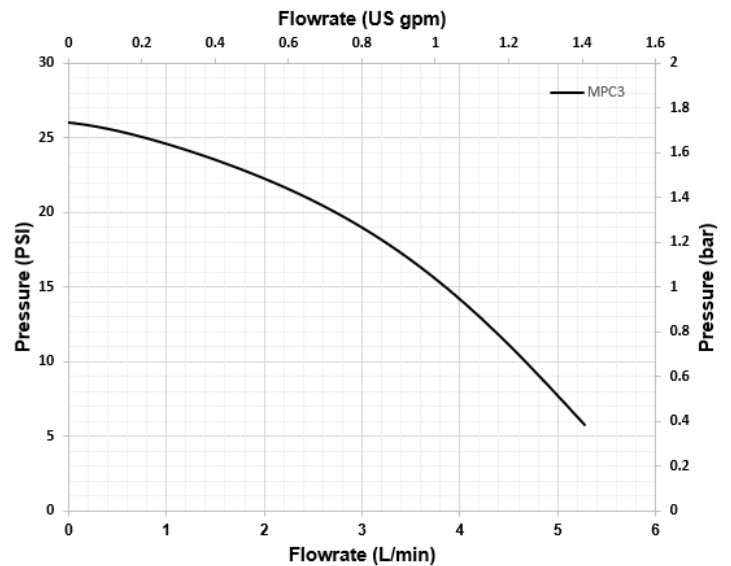



Applied Thermal Control Ltd
 39 Hayhill Industrial Estate
 Barrow-upon-Soar, Loughborough
 LE12 8LD, United Kingdom
 +44 (0) 1530 839 998
 Service@thermalexchange.co.uk
 Support@app-therm.com

Installation, Operation & Service Manual

M05

DOCUMENT DETAILS

Date	16/MAR/2023	Author(s)	MJH	Page	4 / 5	Revision	6
------	-------------	-----------	-----	------	-------	----------	---

SAFETY NOTICES

For your safety, we draw your attention to the following warning and caution marks throughout the manual; the safe operation of an ATC chiller always remains the responsibility of the operator. This equipment is intended to be used as a liquid temperature conditioning device – it requires no external pump, nor any further manipulation of temperature. If the equipment is used in a manner not specified by the manufacturer, the protection provided by the equipment may be impaired.



Caution; Failure to comply with a caution will invalidate product warranty and absolve ATC from any liability, howsoever caused, and could result in permanent damage to equipment.



Caution; Filling/topping up of the tank should only be undertaken with the unit switched off, to prevent back-filling of the fluid.



Caution; The high integrity refrigeration system contains no user-serviceable parts. Repair and service requires specialized knowledge and tools to be provided by ATC or its local agent. Any unauthorized tampering with the refrigeration system automatically invalidates warranty.



Warning; Very cold surfaces and gases, lower than -20°C (-40°F). Severe frostbite hazard.



Warning; Opening the refrigeration system may expose the operator to toxic and corrosive compounds (HFCs). Take protective measures including suitable eye protection.



Warning; Gases may exceed 15 barg (220psig) during operation.



Warning; Refrigerant is class A1. It does not support combustion but is oxygen depleting. Refrigerant charge in the Mini is 360g (12.7oz) of R134a.



Warning; Water and electricity are in close proximity. Always ensure the unit is isolated before service. The Mini is protected from overcurrent by mains fusing. Never bypass this component.



Warning; Failure to comply with a 'warning' may result in personal injury or death. ATC does not accept any liability for injury caused through use of this equipment.



Warning; After switching off, the fan blades slow to a stop. Do not open until the fan has stopped rotating.



Affixed to the chiller's fan, this symbol printed on yellow background advises of the possible damage to fingers or other extremities from rotating fan blades. Allow blades to stop before service begins.



Applied Thermal Control Ltd
39 Hayhill Industrial Estate
Barrow-upon-Soar, Loughborough
LE12 8LD, United Kingdom
+44 (0) 1530 839 998
Service@thermalexchange.co.uk
Support@app-therm.com

Installation, Operation & Service Manual

M05

DOCUMENT DETAILS

Date	16/MAR/2023	Author(s)	MJH	Page	5 / 5	Revision	6
------	-------------	-----------	-----	------	-------	----------	---

INCLUDED ANNEXES

Specific technical product information is provided in the following series of annexes.

Annex A-1 220310 Shipping & Unpacking - Crane or forklift not typically necessary

Annex B-1 191122 Mini & EcoMini site and environmental requirements

Annex C-1 220311 Installation - Generic air-cooled with Pushfit or CPC adapters

Annex D-1 220623 Fluid Handling & Startup Procedures - Mini & R05

Annex E-17 Coolmay Mini Touchscreen

Annex F-1 230316 Pressure and flow adjustment in mini chiller with centrifugal pump

Annex G-1 220623 Troubleshooting - Initial help for Mini & R05

Annex H-1 191121 Generic periodic maintenance for end users

Annex I-1 210830 Maintenance for technicians - Generic refrigerated units

Annex J-1 220406 EU DoC EcoMini & Mini series

Annex J-5 210303 EU Compliance Statement Conflict Minerals

Annex J-7 210303 EU Compliance Statement REACH

Annex J-8 210303 EU Compliance Statement POPs

Annex K-1 200623 Standard warranty terms of ATC

Annex L-11M 190503 RS485 ModBUS RTU for Mini

Annex M-1 220623 Recommended spares, M-, EM-, R05-Series

Annex R-1 200401 SDS Refrigerant HFC-R134a

Annex R-3 200203 SDS Hexid A4 v6.4



Applied Thermal Control Ltd
 39 Hayhill Industrial Estate
 Barrow-upon-Soar, Loughborough
 LE12 8LD, United Kingdom
 +44 (0) 1530 839 998
 Service@thermalexchange.co.uk
 Support@app-therm.com

Annex A-1

DOCUMENT DETAILS

Date	11/MAR/2022	Author(s)	MJH	Page	1 / 1	Revision	1
------	-------------	-----------	-----	------	-------	----------	---

CRANE OR FORKLIFT NOT TYPICALLY NECESSARY

This guide applies to products that can conceivably be lifted/positioned by one or more persons without the aid of machinery. Upon reviewing recommendations below, you may opt to use machinery. This is at your discretion. ATC are not responsible for injury or death sustained through improper handling procedures.

UNPACKING

- 1 Please check that both the packaging and the unit are undamaged. If there is any doubt, it is vital that you inform both ATC and the carrier. There are no hidden shipping bolts or other fixings. You should inspect the packaging for signs of transit damage before signing for the unit, and if possible, unpack the unit before signing. Once you have signed for the goods, ATC cannot be held responsible for any transit damage subsequently found.
- 2 Remove the unit from its original packaging and ensure that there is no packaging left around the cooling ducts. There is no internal product packaging that requires the chiller to be opened.
- 3 Please retain all packaging in the unlikely event that the chiller needs to be returned to our local representatives.

MANUAL HANDLING RECOMMENDATIONS

- 4 For UL compliance, ATC must make the statement; "as the unit is >18kg, ATC must recommend that 2 persons are used to lift by hand, or a crane".
- 5 Your region's workplace safety regulations may differ. The below information is provided as a guideline only in the absence of any other regulations. It is based on the United Kingdom's 'Manual Handling Operations Regulations (1992)'.
 Lifting items of any weight can cause injury if handled incorrectly, depending on what the load is and the physicality of the person handling it. Manual handling guidelines suggest that the maximum safe lifting weight for a woman is 16kg and the maximum safe lifting weight for men is 25kg. These recommendations change depending on the height the object is lifted to and how the object is carried, outlined in the tables below.

Recommendations for Men			
	Height Object is Lifted	Max Weight Held Close to Body	Max Weight at Arm's Length
	Head Height	10kg	5kg
	Shoulder Height	20kg	10kg
	Elbow Height	25kg	15kg
	Knuckle Height	20kg	10kg
	Mid-Lower Leg Height	10kg	5kg

Recommendations for Women			
	Height Object is Lifted	Max Weight Held Close to Body	Max Weight at Arm's Length
	Head Height	7kg	3kg
	Shoulder Height	13kg	7kg
	Elbow Height	16kg	10kg
	Knuckle Height	13kg	7kg
	Mid-Lower Leg Height	7kg	3kg

When two people are lifting an item, the approximate rule is that you should not exceed 2/3rds of the sum of both individual's lifting limits. If two men who can carry a maximum of 25kg each are lifting an object together, then the object should not weigh more than around 33kg. If three people are lifting an object, the maximum weight of this object should not exceed half the sum of all individual's lifting limits.



Applied Thermal Control Ltd
39 Hayhill Industrial Estate
Barrow-upon-Soar, Loughborough
LE12 8LD, United Kingdom
+44 (0) 1530 839 998
Service@thermalexchange.co.uk
Support@app-therm.com

Annex B-1

DOCUMENT DETAILS

Date November 2019

Compiled by MJH

Revision 1

SITE & ENVIRONMENTAL REQUIREMENTS

- a) **Hard, level surface** – Feet on the Mini provide a degree of friction on most work surfaces to prevent sliding. A level surface is important for ensuring proper filling and allowing air to escape.
- b) **Clean, dust-free environment** – air-cooled chillers move large volumes of air, and large amounts of air-borne contamination will result in fouling of the condenser, reducing the capacity of the unit and in extreme cases causing a system shut-down.
- c) **Non-condensing ambient** – +5°C to +40°C (+39°F to +104°F). Capacity is lost above +30°C (+86°F).
- d) **Humidity** - 80% for ambient temperatures up to +31°C (+88°F), decreasing linearly to 50% relative humidity at +40°C (+104°F) ambient temperature.
- e) **Electrical supply** – the Mini comes with a Switch Mode Power Supply capable of accepting;
 - a. Voltage fluctuations of $\pm 10\%$ of the nominal voltage.
 - b. Frequency of 47Hz to 63Hz inclusive.
 - c. Maximum current draw of 5.8A@100VAC; mains fusing is rated 6.3A, accessible from rear.
 - i. See product rating label for fuse specification.
 - ii. Two modes of supply are acceptable; **L1 / N / E** or **L1 / L2 / E**
 - iii. The inlet module itself is rated 10A 250V.
 - iv. Protective earth must be provided by user at IEC type C14 appliance inlet.
- f) **Clearance** – left and right of the unit require clearance of $\geq 300\text{mm}$ ($\geq 11.8''$). Care must be taken to prevent the recirculation of rejected hot air, back into the condenser. This will result in damage if repeated. Ensure there is sufficient room at the rear of the product to remove the power cable without obstruction.
- g) **Plumbing** – tubing, piping or hose must be clean and compatible with the fluid to be used. The chiller is compatible with deionized water and water-glycol mixtures such as Hexid fluid.
- h) **Indoor use only** – altitude up to 2000m.
- i) **Installation category** – transient overvoltage category II; Pollution degree 2. Temporary overvoltages occurring on mains supply are acceptable within limits defined in the aforementioned categories.



Caution; Always use ATC recommended fluids in your chiller – many other anti-freeze mixtures have the potential to corrode your application and to damage seals in the chiller.



Applied Thermal Control Ltd
39 Hayhill Industrial Estate
Barrow-upon-Soar, Loughborough
LE12 8LD, United Kingdom
+44 (0) 1530 839 998
Service@thermalexchange.co.uk
Support@app-therm.com

DOCUMENT DETAILS

Date	11/MAR/2022	Author(s)	MJH	Page	1 / 2	Revision	2
------	-------------	-----------	-----	------	-------	----------	---

INSTALLATION FOR AIR-COOLED UNITS WITH PUSHFIT OR QUICK-RELEASE ADAPTERS

This guide applies to the following product groups;

- M-Series refrigerated units, in the MA485 chassis, with or without an SA00016 options pack.
- A-Series airblast units, in the MA485 chassis, with or without an SA00016 options pack.

HOSE RECOMMENDATIONS

Having ensured that your installation meets all site requirements, it is best practice that the fluid lines between your application and the chiller have the following characteristics.

1	Short in length – this reduces friction-based pressure drop and addition ambient heat load.
2	Large diameter bore – at least 12mm (1/2").
3	Free from 90° bends – to limit the effects of water hammer. If this cannot be avoided, sharp changes of direction should be minimized so far as possible. Doing this correctly can yield higher pump performance and extend time between maintenance intervals. It will also reduce electrical energy consumption.
4	Clean – If your installation is to existing pipe work, it is good practice to flush the system with either a commercially available central heating cleaner or 5% acetic acid solution. The system should be flushed clean with tap water to remove all traces of cleaner prior to filling the system. Failing this, it is recommended to use a domestic bleach in solution with tap water, diluted to the point where the bleach can longer be smelled by human nose.
5	Opaque, ideally black – to inhibit light passing through the tube and algae building up. Alternatively, solid ABS or copper pipe can be used where application chemistry allows.
6	Insulation, where low temperature process is planned – the process line from chiller to application contains the feed of low temperature fluid. Insulation prevents heat from entering this line and can promote better stability. Uninsulated return lines are helpful where free cooling can be obtained by allowing heat to transfer to air – likewise, insulating the return line is helpful if the fluid temperature is below ambient.



Caution; Never use transparent tubing. UV light will pass through, prompting growth of organic contamination.

CONNECTING ADAPTERS TO PRODUCT

1	Standard units are supplied with 12mm pushfit female connections. These fittings are not valved and will 'drop' the volume of the system if left open to atmosphere.
2	Ensure the tube selected to connect to the product has been cut square to the centerline of the tube. Cutting at an angle increases the chances that only a partial seal will be achieved. Pushfit fittings can sometimes feel as though they're pushed fully-home into the connector, but only be halfway in – ensure the tube is pressed in.
3	Pushfit connectors supplied are natively 12mm – while you may be able to find 1/2" tube and operate successfully, other metric to imperial conversions are more difficult. Try to source metric tube.
4	Tube selected must be relatively stiff. Polyurethane and Nylon are good choices. Silicon can often be too soft and alignment/support is critical for harder materials like copper. If using Polyurethane tube, ensure you have selected ether-based. Ester-based is not suitable for water.
5	Ensure that the system is correctly connected. The labels at the ports are clearly marked with ISO7000 standard inlet and outlet symbols. Ports marked as outlet means fluid leaves the product and must be connected to the process inlet. Check all joints are tight and leak free.
6	If your product has the optional SA00016 pack applied, you will have a valved connection. Disconnecting the fittings will retain system volume in the chiller and in the connected tube/hose.
7	Where this product is incorporated into other equipment, it is the responsibility of the assembler to ensure safety.



Applied Thermal Control Ltd
39 Hayhill Industrial Estate
Barrow-upon-Soar, Loughborough
LE12 8LD, United Kingdom
+44 (0) 1530 839 998
Service@thermalexchange.co.uk
Support@app-therm.com

Operating Manual; Installation

Annex C-1

DOCUMENT DETAILS

Date	11/MAR/2022	Author(s)	MJH	Page	2 / 2	Revision	2
------	-------------	-----------	-----	------	-------	----------	---

BACKFILLING

- 1 In situations where the chiller is situated physically lower than the application being cooled, fluid will apply pressure to the water circuit of the product.
- 2 The weakest seal is normally the tank lid, and this is typically where fluid will escape the unit.
- 3 Ideally, the product will be located higher or level with the product water-line. If this is not possible, a non-return solenoid valve kit can be installed as an optional standard assembly.
- 4 Please raise any questions with the sales team on sales@app-therm.com.



Annex D-1

DOCUMENT DETAILS

Date	23/JUN/2022	Author(s)	MJH	Page	1 / 1	Revision	2
------	-------------	-----------	-----	------	-------	----------	---

FILLING, STARTING & DRAINING OF MINI & R05 PRODUCTS

This annex describes the filling, starting, and draining processes associated with standard Mini and R05 products. It differs from other ATC chillers/coolers primarily through the user's interaction with the touchscreen interface. Read this guide in its entirety before starting the process. You should have hoses connected and made best efforts to ensure joints are watertight before starting.

FILLING & STARTING

- 1** **Connect the chiller to the electrical supply and switch on at the rear rocker switch.** The controller should begin to load and leave you on the splash screen with ATC logo in the middle.
- 2** **Check all application valves are open, including solenoid valves and variable position valves.** The chiller will require an open water circuit to pump into. Any obstructions can increase the time, or entirely prevent the bleeding of air from the system.
- 3** **Remove the cap from the tank lid.** On the Mini, this is at the rear on top. On the R05 this is on the front panel. Fill the tank to leave 10-20mm (0.4-0.8") of air between water line and where the lid seals.
- 4** **Turn your attention to the screen on the front of the chiller.** Above the settings 'gear' icon, you will see a pump icon. Holding this icon will manually run the pump, and it will ignore any interlock provided by the level switches. Hold the button until the water line drops to just above the outlet port, then release.



Caution; Do not run the pump dry. Do not deadhead the pump.

- 5** **Repeat the process of filling and manually running the pump.** When the level no longer drops when the pump is run, the unit is filled but we still need to ensure trapped air has been allowed out.
- 6** **Start the chiller by holding the green process start button in the top right.** Leave the cap off the tank for >30mins to allow air to escape. Whilst running, the tank illustration on the user interface ought to stay green and full.
- 7** **Be aware of the prospect of trapped air becoming compressed in the system.** When the chiller is turned off, the compressed air expands and can push fluid through the tank lid. To avoid this, allow any drop in level to occur without topping-up early in the 30min air-bleeding cycle. Whilst not foolproof, this is the best way to avoid backfilling.
- 8** **Check the application and tubing for signs of leaks whilst the chiller is running.** Replace the tank lid when satisfied the system is full and bled of air.

DRAINING

- 1** **On both R05 and Mini, open the ports to gravity-drain the plate heat exchanger and return line.** Use the manual priming button on the touchscreen to empty the tank via the discharge line. Do not run the pump dry. You may also use a manual siphon tube to empty the tank, although the R05 neck is narrow and should be measured first. Never turn a chiller upside-down.



Applied Thermal Control Ltd
 39 Hayhill Industrial Estate
 Barrow-upon-Soar, Loughborough
 LE12 8LD, United Kingdom
 +44 (0) 1530 839 998
 Service@thermalexchange.co.uk
 Support@app-therm.com

DOCUMENT DETAILS

Date	14/03/2023	Author(s)	WSE	Page	1 / 8	Revision	1
------	------------	-----------	-----	------	-------	----------	---

Annex E-17 C-P-4.3-12D2X5V2NTC-4T8R-2X5V-N Mini Touchscreen

Splash Screen

Upon first powering on, the chiller will arrive at this page after a software loading sequence is complete.

1. Process start/stop (Start/stop fridge and water circuit).
2. Pump priming toggle button runs pump without process starting.
3. Next Page.
4. Access to settings menu. (See *Passcode Entry*)
5. Serial number is added by ATC during production.
6. Process outlet temperature. (Green = in range/Red = out of range).
7. Process Set Point.
8. PID Standby/Percentage output.

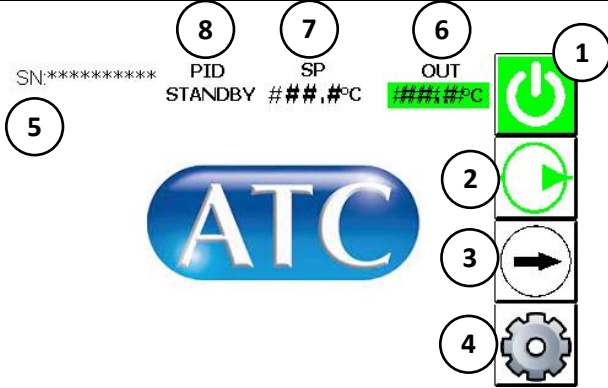

Process View

1. Process Start/Stop.
2. Set outlet temperature.
3. Next page.
4. Process outlet temperature. (Green = in range/Red = out of range).
5. Compressor utilization.
6. Tank level status.
 Green = Full
 Amber = Top-up
 Red = Low level (Chiller will automatically switch off to protect internal components)

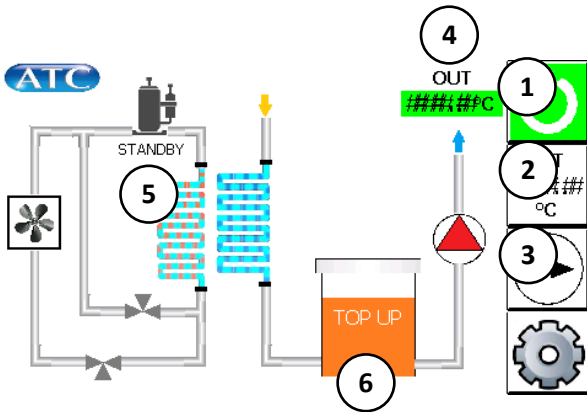

Simple View

1. Actual outlet temperature. (Green = in range/Red = out of range).
2. Setpoint temperature.
3. Tank level status.

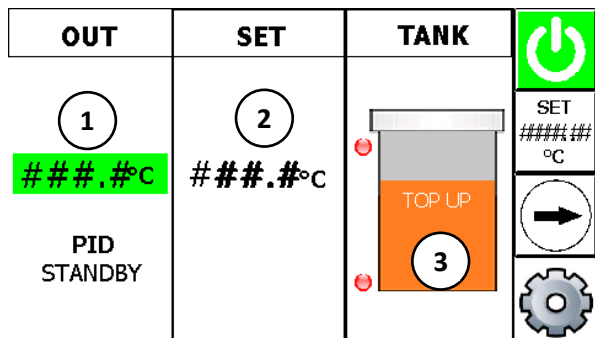



DOCUMENT DETAILS

Date 14/03/2023 Author(s) WSE Page 2 / 8 Revision 1

ENGINEERING VIEW 1			
PARAMETER	VALUE		
PROCESS TIMES	DD:HH:MM:SS	SET	[Power Icon]
CURRENT UP TIME	##:##:##:##	####/# °C	
SYSTEM UP TIME	##:##:##:##	[Right Arrow Icon]	[Gear Icon]
COMPRESSOR	##:##:##:##		
FAN	##:##:##:##		
PUMP	##:##:##:##		

Engineering View

1. When illuminated red, tap to move to error view (below).
2. Scroll down to ENGINEERING VIEW 2 parameters.

ERRORS			
		SET	[Power Icon]
		####/# °C	
		[Right Arrow Icon]	
		[Gear Icon]	

Error View

1. Clear error lists.
2. Scroll down through error list.

Error Codes

1. Comp. overload/locking.
2. Comp. disconnected.
3. Comp. overcurrent.
4. Comp. abnormal VDC.
5. Comp. overheat.
6. Tank low.
7. Threshold Minimum.
8. Threshold Maximum.
9. PT100 disconnected.
10. MODBUS error.

MAINTENANCE DUE 1			
		SET	[Power Icon]
	MM/YY ##/##/##	####/# °C	
	DD/MM/YY ##/##/##	[Right Arrow Icon]	
	DD/MM/YY ##/##/##	[Gear Icon]	

Maintenance Prompt View

1. Move up the parameter list.
2. Move down the parameter list.
3. Date is editable, tap to adjust next check date.
4. Exclamation mark is shown for overdue. Tap to confirm check made.
5. Tick mark is shown by black text for maintenance not due.

Number Input

1 *****

max.: *****
min.: *****

7	8	9	Clear
4	5	6	Esc
1	2	3	Back
.	0	-	OK

Passcode Entry







Pressing the settings gear icon shows the passcode screen.

Enter 4321 to enter factory settings.
 Enter 1234 to enter user settings.

1. Passcode appears in box above keyboard.
2. Select OK to use passcode.
3. Select Clear to clear passcode input.
4. Select Esc to return to main screen.

DOCUMENT DETAILS





Date 14/03/2023 Author(s) WSE Page 3 / 8 Revision 1

USER SETTINGS 1			
PARAMETER			
 3	UNITS OF MEASURE	4 DATE & TIME MENU	SET ##### °C
5 	DISPLAY SETTINGS MENU		 2
 1			

User Settings (1)





Screen available after successfully entering the passcode.

1. Down arrow scrolls through user settings pages.
User settings are a cut-back version of factory settings.
2. Return to main carousel.
3. Select required units of measure (Deg C, Deg F, Deg K)
4. Set date & time.
5. adjust display options (Brightness & touch volume)

UNITS OF MEASURE			
PARAMETER			
 1	SET CELSIUS FAHRENHEIT KELVIN	2 °C	SET ##### °C
	PID % / -	-	
		3	





Units of measure

1. Choose Deg C, F or K for Setpoint temperature units.
2. Choose Deg C, F or K for Process outlet temperature units.
3. Set PID output scale to %.

Date / Time			
PARAMETER			
 1	Day ##	2 ##	SET ##### °C
	Month ##	3 ####	
	Hour ##	4 ##	
	Minute ##		
	Day of Week #	5 SUNDAY	

Units of measure

1. Enter Day in DD
2. Enter Month in MM
3. Enter Year in YY
4. Enter Hour/Minute in 24h
5. Enter day of week in numerical value e.g. 1=Monday, 7=Sunday

DISPLAY SETTINGS			
PARAMETER			
 1	BRIGHTNESS % ###	2 ###	SET ##### °C
	TOUCH VOLUME %		
			

Display settings

1. Set screen brightness (40-100%)
2. Set Touch volume (10-100%)



DOCUMENT DETAILS

Date 14/03/2023 Author(s) WSE Page 4 / 8 Revision 1

USER SETTINGS 2			
PARAMETER			
1	1 USER PIN SETTING	2 MODBUS MENU	SET ##### °C

User Settings (2)

Scroll down from 'User Settings' (1)
 Further to 'Passcode Entry' above;

- To access higher level settings, the user settings PIN can be edited while access has been gained to 'Factory Settings'.
- Edit RS485/MODBUS settings

USER PIN SETTINGS			
PARAMETER			
1	1 USER SETTING PIN ####	2 RESET TO DEFAULT	SET ##### °C

User pin settings

- Edit user pin
- Reset user pin (Default, 1234)

MODBUS COMMS.			
PARAMETERS			
1	Slave Address ###	Data Format ####	2 SET ##### °C
	Baud Rate 9600	Data Bits 8	Stop Bits 1
	Parity NONE	ODD	EVEN
	6		

MODBUS comms parameters

- Slave address (Default, 0)
- Data format (Default, E080)
- Baud rate (Default, 9600)
- Data bits (Default, 8)
- Stop bits (Default, 1)
- Parity (Default, None)

FACTORY SETTINGS 1			
PARAMETER			
1	1 MACHINE INFO.	2 LIMITS / ALARMS MENU	SET ##### °C
	3 COMPR. SETTINGS MENU	4 SETPOINTS MENU	
	5 FACTORY PIN SETTING	6 MAINTENANCE MENU	

Factory Settings (1)

- Machine info (Serial #, HMI software version, Commissioning date, Controller version)
- Limits/Alarms menu
- Compressor settings menu (Compressor min/max voltages, Compressor stop vale)
- Setpoints Menu (Default SP, min/max SP, Threshold envelope min/max for out of temp range output warning, enable default SP on startup)
- Factory pin setting (Change factory or user pin or reset to default)
- Maintenance menu



DOCUMENT DETAILS

Date 14/03/2023 Author(s) WSE Page 5 / 8 Revision 1

FACTORY SETTINGS 2			
PARAMETER			
	1 CALIBRATION MENU	2 PID COOLING	SET ##### °C
	3 PID HEATING		

Factory Settings (2)

1. Calibration menu (Adjust NTC probe offset value)
2. PID cooling (Adjust PID, Gain & input filtering, Autotune function)
3. PID heating (Not currently implemented)

MACHINE INFO.			
PARAMETER			
	2 SERIAL # *****	3 HMI SW VER. *****	SET ##### °C
1	4 COMMISSIONING DATE *****	5 CONTROLLER VER. *****	6

Machine Information

1. Return to 'Factory Settings' main menu.
2. Serial number is added here by factory electronically.
3. Display version, not editable.
4. Commissioning date (factory final test run date).
5. Firmware version, not editable.
6. Exit back to main carousel.

LIMITS / ALARMS			
PARAMETER			
	2 PARAMETER 1		SET ##### °C
1			

Limits/Alarms

1. Return to 'Factory Settings' main menu.
2. Parameter name for limit alarm/output.

COMPRESSOR SETTINGS			
PARAMETER			
	2 TEST OFF	Comp. Min. ~ 1.89V ~ 1410 Bits Adjust Bit Value #####	SET ##### °C
1	3 TEST OFF	Comp. Max. ~ 3.76V ~ 2806 Bits Adjust Bit Value #####	
	4 TEST OFF	Comp. Stop ~ 1.64V ~ 1218 Bits Adjust Bit Value #####	

Maintenance Parameters

1. Return to 'Factory Settings' main menu.
- Note; Below settings are not to be adjusted without ATC approval. Do not use 'Test' functions during normal operation.**
2. Compressor min voltage output displayed as a bit value.
 3. Compressor max voltage output displayed as a bit value.
 4. Compressor stop voltage displayed as a bit value.



DOCUMENT DETAILS

Date 14/03/2023 Author(s) WSE Page 6 / 8 Revision 1

SETPOINTS MENU				
PARAMETER				
↑	2	DEFAULT SETPOINT ###.#°C	3 NO	SET ##### °C
↶	4	MINIMUM SETPOINT ###.#°C	5 THRESHOLD Min. °C Max. ###.# ###.#	←
↓	6	MAXIMUM SETPOINT ###.#°C	7 Min. °C Max. ###.# #####	⚙️

Setpoint Manu

1. Return to 'Factory Settings' main menu.
2. Default setpoint on startup.
3. Toggle enable/disable default setpoint on startup.
4. Minimum setpoint.
5. Out of temperature range threshold envelope.
6. Maximum setpoint.
7. Min/max value the out of temperature range the alarm will output a fault, based off the current setpoint value.

FACTORY PIN SETTINGS				
PARAMETER				
↑	2	FACTORY SET PIN ####	3 RESET TO DEFAULT	SET ##### °C
↶	4	USER SETTING PIN ####	5 RESET TO DEFAULT	←
↓				⚙️

Factory pin settings

1. Return to 'Factory Settings' main menu.
2. Set the Factory pin.
3. Reset factory pin to default (4321).
4. Set the User pin.
5. Reset the User pin to default (1234).

MAINTENANCE 1				
PARAMETER				
↑	2	PARAMETER 1 *****	PARAMETER 2 *****	SET ##### °C
↶	1	PARAMETER 3 *****	PARAMETER 4 *****	←
↓		PARAMETER 5 *****	PARAMETER 6 *****	⚙️

Maintenance 1

1. Return to 'Factory Settings' main menu.
2. Set parameter of required maintenance headers.

CALIBRATION				
PARAMETER				
↑	2	OUT Offset ###.#°C	3 Raw Value ###.#°C	SET ##### °C
↶	1			←
↓				⚙️

Calibration

1. Return to 'Factory Settings' main menu.
2. Adjust the NTC process temperature probe offset value.
3. NTC process temperature probe raw data input value.



DOCUMENT DETAILS

Date 14/03/2023 Author(s) WSE Page 7 / 8 Revision 1

COOLING PID SETTINGS 1			
PARAMETER			
↑	2	Integral Time ####	Proportional Gain #### °C
←	4	Derivative Time ####	Differential Gain ###
↓	6	Input Filtering ###	

Cooling PID settings

1. Return to 'Factory Settings' main menu.
2. Integral time
3. Proportional gain
4. Derivative time
5. Differential gain
6. Input filtering

COOLING PID SETTINGS 2			
PARAMETER			
↑	2	Autotune Autotune	Output Bits #### °C
←	4	PV ####°C	

Setpoint Defaults

1. Return to 'Factory Settings' main menu.
2. Autotune function (Not implemented)
3. PID output display in bits
4. Current PV



DOCUMENT DETAILS

Date 14/03/2023 Author(s) WSE Page 8 / 8 Revision 1

RS485/MODBUS Address chart

Coil	Parameter
0	Pump in manual.
1	Start / Stop.
8	Pump running.
100	Compressor Overload / Locking
101	Compressor Disconnected
102	Compressor Overcurrent
103	Compressor Abnormal DC Voltage
104	Compressor Overheat
105	Tank Empty
106	Threshold Minimum
107	Threshold Maximum
108	PT100 Open circuit
109	Modbus Error
110	Spare

Holding Register	Parameter
10	Maintenance 1 Day
11	Maintenance 1 Month
12	Maintenance 1 Year
13	Maintenance 2 Day
14	Maintenance 2 Month
15	Maintenance 2 Year
16	Maintenance 3 Day
17	Maintenance 3 Month
18	Maintenance 3 Year
19	Maintenance 4 Day
20	Maintenance 4 Month
21	Maintenance 4 Year
22	Maintenance 5 Day
23	Maintenance 5 Month
24	Maintenance 5 Year
25	Maintenance 6 Day
26	Maintenance 6 Month
27	Maintenance 6 Year
28	Maintenance 7 Day
29	Maintenance 7 Month
30	Maintenance 7 Year
31	Maintenance 8 Day
32	Maintenance 8 Month
33	Maintenance 8 Year
34	Maintenance 9 Day
35	Maintenance 9 Month
36	Maintenance 9 Year
131	Setpoint Input for Deg. C (Read / Write) Integer, 250 = 25.1 deg. C
132	Setpoint Input for Deg. F (Read / Write) Integer, 655 = 65.5 deg. F
133	Setpoint Input for Kelvin. (Read / Write) Integer, 2751 = 275.1 K
140	Current Setpoint mode; Celsius = 0 / Fahrenheit = 1 / Kelvin = 2 (Read)
144	Current Output mode; Celsius = 0 / Fahrenheit = 1 / Kelvin = 2 (Read)



Applied Thermal Control Ltd
39 Hayhill Industrial Estate
Barrow-upon-Soar, Loughborough
LE12 8LD, United Kingdom
+44 (0) 1530 839 998
Service@thermalexchange.co.uk
Support@app-therm.com

Annex F-1

DOCUMENT DETAILS

Date	29/NOV/2019	Compiled by	MJH	Revision	1
------	-------------	-------------	-----	----------	---

PRESSURE AND FLOW ADJUSTMENT IN MINI CHILLER WITH CENTRIFUGAL PUMP

The Mini is available with a range of pump options. Low pressure requirements are best served by the quieter and mechanically looser centrifugal types – the flow of these items is dictated by the backpressure of the pipework through which it must pump. Reviewing the pump flow curve can indicate the flow expected. Centrifugal pumps have such a limited maximum pressure, that the water circuit components alone can hold the pressure, and no pressure relief valve is fitted.

If further limitation of pressure is required, a flow control valve can be fitted to either the outlet or inlet of the chiller, depending on whether the application is to be pressurized or not.



Applied Thermal Control Ltd
 39 Hayhill Industrial Estate
 Barrow-upon-Soar, Loughborough
 LE12 8LD, United Kingdom
 +44 (0) 1530 839 998
 Service@thermalexchange.co.uk
 Support@app-therm.com

Operating Manual; Troubleshooting Annex G-1

DOCUMENT DETAILS

Date	23/JUN/2022	Author(s)	MJH	Page	1 / 1	Revision	2
------	-------------	-----------	-----	------	-------	----------	---

MINI & R05 GENERIC INITIAL TROUBLESHOOTING

Symptom	Potential Cause(s)
Compressor not running	Check the connection of the compressor power plug situated on top of the compressor itself.
	Check the connection of the signal line from the controller to the compressor PCB control board.
	The compressor has built-in logic issued via its PCB control board – board error states are communicated to the main touchscreen controller.
Noisy operation	Usually bearing failure in rotating machinery causes noise – this might be the cooling fan, the compressor or the pump. Pay attention to specific components to identify the source of noise.
Fluid lines becoming fouled / containing biological matter	Not using opaque tubing can lead to UV light passing through the tubing, prompting growth of organisms.
	Not following maintenance schedule for cleaning/flushing.
Fluid seen leaking from system	Your fluid may be incompatible with the materials used in chiller construction. Contact ATC to ensure the fluid is compatible.
	Rapid changes in system temperature can cause some materials to change shape at a faster rate than others. Contact ATC to discuss alternative materials and parts in water circuit construction.
Poor cooling capacity (undercooling)	Check for any error states on the compressor – the controller will indicate if an error has occurred – tapping to clear will allow refrigeration to continue.
	This can be caused by 1) excess application thermal heat load, 2) excess ambient temperature, 3) fan failure, or 4) controller issues with fan speed or compressor control.
Excess cooling capacity (overcooling)	Check behavior of heating solenoid valve – if no power reaches the coil, or if it jammed closed, cooling may continue to occur.
	Check value that system seeing for 'OUT' liquid temperature. A value reported that is higher than actual will force the system to cool without need.
Following period of being powered-down, chiller no longer retains correct time and date settings.	When no mains power is provided to the chiller, a PCB-mounted button cell is used to power the real time clock (RTC). This is a lithium cell with Panasonic part number BR-1225/BN. The item is UL-approved under file number MH12210. ATC provide approved replacements.



Applied Thermal Control Ltd
 39 Hayhill Industrial Estate
 Barrow-upon-Soar, Loughborough
 LE12 8LD, United Kingdom
 +44 (0) 1530 839 998
 Service@thermalexchange.co.uk
 Support@app-therm.com

Operating Manual; Maintenance for End-Users

Annex H-1

DOCUMENT DETAILS

Date November 2019

Compiled by MJH

Revision 1

PERIODIC MAINTENANCE REQUIREMENTS BY END USER



Caution; Failure to carry out service at the specified intervals may permanently damage your equipment.

Print this sheet out and display close to the chiller to maximize the visibility of maintenance requirements.

Weekly	Week 1	Week 2	Week 3	Week 4
Check fluid level – top up as required.				

Monthly	J	F	M	A	M	J	J	A	S	O	N	D
Check the condenser is free from dust or accumulation of debris.												

Annually	Y1	Y2	Y3	Y4	Y5	Y6	Y7	Y8
Drain process fluid and replace with fresh fluid.								
Check for fluid leaks throughout chiller and application.								
Clear any debris from inside the chiller.								

A vacuum cleaner is recommended for cleaning out the condenser, while soft cloths and IPA are recommended for cleaning metallic surfaces. If any spillages have occurred, best practice is to allow the water to evaporate off and wipe up remaining glycol residue with a cloth. Always clean with power supply isolated.



Caution; Never blow out the condenser with compressed air.



Caution; If the mains lead is lost or damaged, contact ATC who will be able to supply a replacement of the correct specification.



Applied Thermal Control Ltd
39 Hayhill Industrial Estate
Barrow-upon-Soar, Loughborough
LE12 8LD, United Kingdom
+44 (0) 1530 839 998
Service@thermalexchange.co.uk
Support@app-therm.com

Annex I-1

DOCUMENT DETAILS

Date	30/AUG/2021	Author(s)	MJH	Page	1 / 1	Revision	3
------	-------------	-----------	-----	------	-------	----------	---

GENERIC MAINTENANCE FOR TECHNICIANS



Warning; Opening the refrigeration system may expose the operative to toxic and corrosive compounds (HF). Take protective measures including suitable eye protection.



Warning; Gases may exceed 300 psi (20 bar) during operation.



Warning; Refrigerants do not support combustion (A1-class), but do displace air (oxygen), presenting asphyxiation risk.



Warning; After switching off, the condenser cooling fan blades continue to rotate. Do not attempt servicing whilst the blades are rotating.



Warning; All chillers contain water and electricity in close proximity. Ensure the unit is isolated before service. This product is protected from overcurrent by fuses (or MCB) on the mains inlet. Never bypass the overcurrent protection.

Following service or repair by a trained technician;

- a) Ensure any electrical connections that may have been disturbed are given the 'tug-test'
- b) Ensure earth bonding conductors are re-attached.
- c) Ensure the correct fuses are in place.
- d) Ensure the mains cord being used is to specification, and is free from damage
- e) Subject the unit to a PAT test to ensure the unit is safe before running.
- f) Ensure there are no leaks inside or outside the unit.
- g) Using the wiring schematic for guidance, simulate faults to check each interlock's function.



Applied Thermal Control Ltd
39 Hayhill Industrial Estate
Barrow-upon-Soar, Loughborough
LE12 8LD, United Kingdom
+44 (0) 1530 839 998
Service@thermalexchange.co.uk
Support@app-therm.com

Operating Manual; Declarations & Approvals

Annex J-1

DOCUMENT DETAILS

Date	6/APR/2022	Author(s)	MJH	Page	1 / 1	Revision	1
------	------------	-----------	-----	------	-------	----------	---

EU DECLARATION OF CONFORMITY

Document layout; Governed by Machinery Directive 2006/42/EC, Annex II.

REGISTERED BUSINESS ADDRESS

Applied Thermal Control Ltd, 39 Hayhill Industrial Estate, Barrow-upon-Soar, Loughborough, LE12 8LD, UK.

AUTHORISED REPRESENTATIVE

Atik Cameras Unipessoal Lda, Rua Horta dos Bacelos, 152690-390 Santa Iria da Azoia, Portugal

DESCRIPTION & IDENTIFICATION OF MACHINERY

Generic denomination;	Mini & ecoMini Series.
Function;	Recirculating chiller
Model;	All with 'M' or 'eM' prefix.
Type;	Air-cooled or water-cooled vapour compression-based.
Serial number;	
Commercial name;	As above.

NOTIFIED BODY

Not applicable

QUALITY ASSURANCE SYSTEM

QMS International Ltd, Muspole Court, Muspole Street, Norwich, NR3 1DJ, UK. ASCB Registered; 201409-2

DECLARATION

Applied Thermal Control declares that the machinery described above fulfils all the relevant provisions of the directives and standards below.

Directive	Harmonised Standards applied
Machinery Directive 2006/42/EC (inclusive Low Voltage Directive 2014/35/EU)	EN ISO 12100:2010 (MD) BS EN 61010-1:2010+A1:2019 (LVD)
EMC Directive 2014/30/EU	IEC 61000-6-2:2005 IEC 61000-6-4:2006 +A1:2011
RoHS Directive 2011/65/EU (RoHS 2) RoHS Directive (EU) 2015/863 (RoHS 3)	EN IEC 63000:2018
Pressure Equipment Directive (2014/68/EC)	Out of Scope. Sound Engineering Practice (SEP) applied.

PERSON EMPOWERED TO DRAW UP DECLARATION

Robert Poniatowski, CEO
Signed in Barrow-upon-Soar, UK, date 14/APR/2025



Applied Thermal Control Ltd
39 Hayhill Industrial Estate
Barrow-upon-Soar, Loughborough
LE12 8LD, United Kingdom
+44 (0) 1530 839 998
Service@thermalexchange.co.uk
Support@app-therm.com

Operating Manual; Declarations & Approvals Annex J-5

DOCUMENT DETAILS

Date	03/FEB/2021	Author(s)	MJH	Page	1 / 1	Revision	01
------	-------------	-----------	-----	------	-------	----------	----

CONFLICT MINERALS COMPLIANCE STATEMENT

Applied Thermal Control (ATC) adheres to and embraces the ethical values that support our everyday activities. As an expression of these principles and ethical values, ATC adheres to the principle of responsible sourcing of components containing precious and non-precious metals and metal salts in compliance with applicable laws and regulations.

The metals considered are Tantalum (Ta), Tungsten (W), Tin (Sn) and Gold (Au). ATC actively sources components from suppliers known to be reputable and could demonstrate compliance upon request with the Conflict Minerals acts and guidelines.

ATC uses Gold and Tin in electrical components, on PCBs and in rotating machinery, as governed by technical requirements of products. These metals could potentially originate from conflict mineral sites. As many of our suppliers do not purchase these metals direct from smelters, both they and ATC must rely heavily on information that will be provided by their suppliers to determine the source and chain of the metals in those products.

ATC is committed to working with its customers and supply chain to meet the customer's specification and requirements with regards to traceability, sourcing requirements and restrictions. ATC commits that, to the best of our knowledge, our suppliers are complying with the conflict minerals act as stated in their documentation. These statements are reviewed, and updates obtained as required.

Robert Poniatowski, CEO
Signed in Barrow-upon-Soar, UK, date 03/FEB/2021



Applied Thermal Control Ltd
39 Hayhill Industrial Estate
Barrow-upon-Soar, Loughborough
LE12 8LD, United Kingdom
+44 (0) 1530 839 998
Service@thermalexchange.co.uk
Support@app-therm.com

Annex J-7

DOCUMENT DETAILS

Date	03/FEB/2021	Author(s)	MJH	Page	1 / 1	Revision	01
------	-------------	-----------	-----	------	-------	----------	----

WHAT IS THE REACH REGULATION 1907/2006?

REACH is a regulation of the European Union, adopted to improve the protection of human health and the environment from the risks that can be posed by chemicals, while enhancing the competitiveness of the EU chemicals industry. REACH places the burden of proof on companies. To comply with the regulation, companies must identify and manage the risks linked to the substances they manufacture and market in the EU. They have to demonstrate to ECHA how the substance can be safely used, and they must communicate the risk management measures to the users. If the risks cannot be managed, authorities can restrict the use of substances in different ways. In the long run, the most hazardous substances should be substituted with less dangerous ones. REACH stands for Registration, Evaluation, Authorization and Restriction of Chemicals. It entered into force on 1/JUN/2007.

REACH 'ARTICLE' COMPLIANCE CONSIDERATIONS

REACH ANNEX XVII COMPLIANCE

Substances under Annex XVII are restricted either in full (not to be used at all) or for specific uses (can be used in some uses but cannot be used in identified uses).

Applied Thermal Control has contacted all our suppliers and to the best of our knowledge, none of the articles that we sell intentionally contain any of the Annex XVII substances currently on the candidate list in concentrations of >0.1% by weight.

REACH ANNEX XIV COMPLIANCE

Substances under Annex XIV require authorization to use in the EU after sunset date, require communication to downstream recipients when over threshold (0.1% w/w at article level) and require notification to ECHA when SVHC over threshold and imported over 1000kg annually and use not already registered.

Applied Thermal Control has contacted all our suppliers and to the best of our knowledge, none of the articles that we sell intentionally contain any of the Annex XVII substances currently on the candidate list in concentrations of >0.1% by weight.

SVHC LIST COMPLIANCE

Substances of Very High Concern (SVHC) require communication to downstream recipients when over threshold (0.1% w/w at the article level), notification to the European Chemicals Agency (ECHA) when SVHC over threshold and when imported over 1000kg annually and use not already registered.

Applied Thermal Control has contacted all our suppliers and to the best of our knowledge, none of the articles that we sell intentionally contain any of the Annex XVII substances currently on the candidate list in concentrations of >0.1% by weight.

DECLARATION

Robert Poniatowski, CEO
Signed in Barrow-upon-Soar, UK, date 03/FEB/2021



Applied Thermal Control Ltd
39 Hayhill Industrial Estate
Barrow-upon-Soar, Loughborough
LE12 8LD, United Kingdom
+44 (0) 1530 839 998
Service@thermalexchange.co.uk
Support@app-therm.com

Operating Manual; Declarations & Approvals Annex J-8

DOCUMENT DETAILS

Date	03/FEB/2021	Author(s)	MJH	Page	1 / 1	Revision	01
------	-------------	-----------	-----	------	-------	----------	----

WHAT IS THE POPs REGULATION 2019/1021?

POPs stands for persistent organic pollutants. In Europe, the global Stockholm Convention is implemented through POPs legislation. POPs are organic substances that persist in the environment, accumulate in living organisms and pose a risk to our health and the environment. They can be transported by air, water or migratory species across international borders, reaching regions where they have never been produced or used. International risk management is necessary as no region can manage the risks posed by these substances alone.

The European Parliament (and Council) issued regulation 2019/1021 on 20/JUN/2019, and further amended (regulation 2020/784) on 8/APR/2020.

POPs LISTED UNDER INITIAL REGULATION 2019/1021

Pesticides;

Aldrin, Chlordane, DDT, Dieldrin, Endrin, Heptachlor, Hexachlorobenzene, Mirex, Toxaphene.

Industrial Chemicals;

Hexachlorobenzene, Polychlorinated Biphenyls (PCBs).

Industrial Chemical Byproducts;

Hexachlorobenzene byproducts;

Polychlorinated dibenzo-p-dioxins and polychlorinated dibenzofurans (PCDD/PCDF), and PCBs.

POPs LISTED UNDER AMENDMENT 2020/784

Perfluorooctanoic acid (PFOA), its salts and PFOA-related compounds.

POPs COMPLIANCE STATEMENT

We certify that to the best of our knowledge, based upon up-to-date information from our suppliers, all products supplied by Applied Thermal Control are fully POPs compliant in accordance with regulations and amendments above mentioned.

DECLARATION

Robert Poniatowski, CEO
Signed in Barrow-upon-Soar, UK, date 03/FEB/2021



Applied Thermal Control Ltd
39 Hayhill Industrial Estate
Barrow-upon-Soar, Loughborough
LE12 8LD, United Kingdom
+44 (0) 1530 839 998
Service@thermalexchange.co.uk
Support@app-therm.com

DOCUMENT DETAILS

Date	03/FEB/2021	Author(s)	RW, MJH	Page	1 / 1	Revision	02
------	-------------	-----------	---------	------	-------	----------	----

WARRANTY TERMS

Please visit the website warranty registration page to ensure ATC can offer you the best possible support;

<https://www.app-therm.com/warranty-registration/>

a) For how long is my ATC product warrantied?

ATC provides a comprehensive return to base 2-year parts, 1-year labor warranty from delivery as standard on all new equipment, provided it has been installed and operated in accordance with the manual.

b) Where will ATC fulfill the product warranty?

ATC's standard warranty terms are Return to Base (RTB) – issues with chillers are often easily solvable over the phone or email, or by reviewing ATC's technical guidance on the web and in the product manual. On occasion, at the discretion of ATC, goods may be serviced on site FOC or a service loan unit may be supplied. Warranty cover excludes the cost of travel by engineers and loan unit rental charges. Obtaining onsite service for a product, even in full warranty, is a chargeable service.

c) Who is liable for shipping charges in the event of warranty failure?

During the **first year** of the warranty period, freight costs for shipping to ATC are for the customer's account. Freight costs for shipping from ATC are for ATC's account.

During the **second year** of the warranty, freight costs to and from ATC are for the customer's account.

d) I'm experiencing problems with my chiller. It's within warranty – what do I do next?

Contact ATC to discuss the issue you are having. The contact details in the header of this document are an ideal place to start. Be sure to have your model number and serial number on-hand to aid those attempting to solve remotely.

e) Telephone support couldn't fix my chiller – what do I do next?

An RMA form must be completed. This allows both the end-user and ATC to clarify your details, to set the party responsible for shipping costs, and to set a different return address if desired. Shipping advice is provided, and the end-user must sign a declaration that states the unit is safe to handle. Return the form by email for fastest response.

f) What happens if my chiller failed outside warranty or requires non-warranty repair work?

A purchase order will be requested to cover an initial inspection – this will only be invoiced if the inspection shows there is no fault. If packaging is required, i.e. a crate, a separate charge will be levied. If the end user prefers ATC to arrange a collection, a shipping charge may be levied.

g) Our process must continue running – can we have a loan unit whilst our chiller is in repair?

ATC hold several standard air-cooled chillers at the factory for the sole purpose of offering for loan – these are available on a first-come, first-serve basis. Models up-to 3kW capacity are available.



**ModBUS® Communication Protocol
for the
ATC MINI Chiller**

**Applied Thermal Controls Limited
39 Hayhill Industrial Estate, Barrow Upon Soar,
Leicestershire, LE12 8LD, UK
Email: sales@app-therm.com
Tel: +44 (0)1530 839998**

OVERVIEW

The ATC MINI Chiller uses the ModBUS® RTU communication protocol over RS485 networks

All communication messages finish with a check sum type CRC (cyclic redundancy check).

Every slave device in a network must have a different address.

The protocol allows one master only and up to 247 slaves.

Only the master unit can start communication by the transmitting the address of the intended slave unit and the command to execute.

Only the slave unit having the matching address will answer to the master.

Remote control via RS485 has priority over local MINI Chiller settings.

The serial transmission characteristics are programmable within the ATC MINI Chiller Parameter Menu Modbus

Settings

Slave device address: 1 to 247

Baud rate: 4800, 9600, 19200, 38400, 115200 bits per second

Byte Format: 1 start bit, 8 data bits, optional parity bit (odd, even, none) and 1 stop bit

2 wire (half duplex) and 4 wire (full duplex) RS485 communication is supported

Termination resistors (120R) are required at each end of the RS485 network

ATC Mini Chiller - ModBUS Communication Protocol

1 Physical Connection

The ATC MINI Chiller is provided with an RS485 serial communication interface, insulated to 1kV so that any problem arising from ground potential is removed. While idle, the MINI Chiller is in a receive condition and only undertakes transmission after a message has been decoded that matches the configured address. If the checksum and data format is correct, an OK is transmitted (code 0) but if an error occurred, an error code (1+) is sent back to the master.

The MINI Chiller is equipped with terminals named Tx+, Tx-, Rx+, Rx- and 0V to support 4 wire (full duplex) or 2 wire (half duplex) networks. The connection between slaves is wired in parallel according to the diagrams below. A termination resistor of 120R is required at either end of the RS485 network wired pairs to prevent signal reflection problems. A common earth or 0V line is preferred to ensure stability and transient suppression within the system. The line can be up to 1000 meters in length and support up to 31 slaves without a repeater buffer.

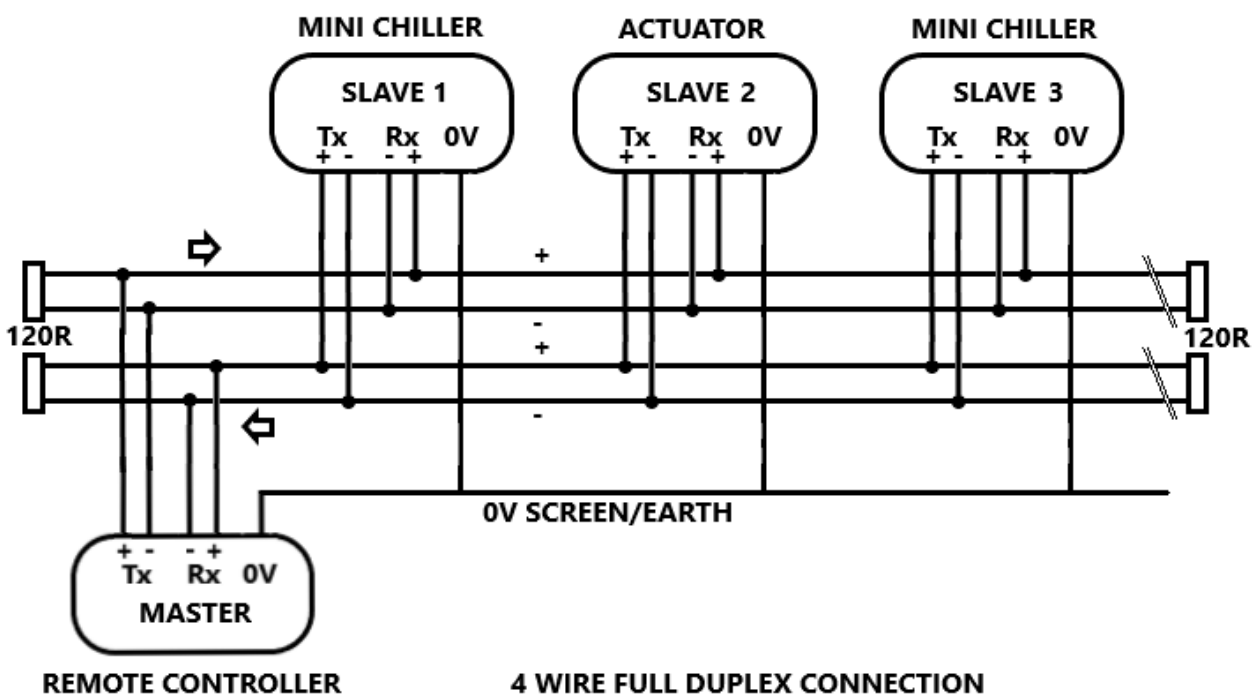
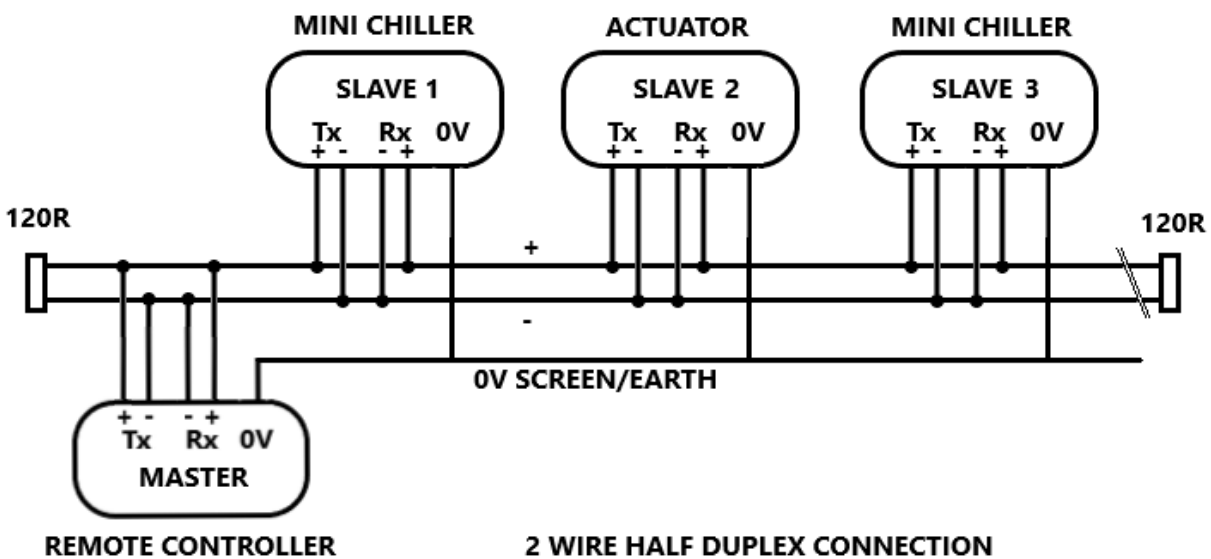

ATC Mini Chiller - ModBUS Communication Protocol

2 Communication Protocol

The protocol adopted by the ATC MINI Chiller is a subset of the widely used MODBUS RTU (JBUS, AEG Schneider Automation, Inc. registered trademark) protocol, so that connections are easy for many commercial PLCs and supervisory programs.

The MODBUS RTU communication functions implemented are:

From master to slave	From slave to master
Function 3: read n registers request	Function 3: return data content of n registers
Function 6: set one register request	Function 6: set one register and acknowledge
Function 16: set multiple registers request	Function 16: set multiple registers and acknowledge

Every message contains four fields: Slave Id, Function, Data, CRC

Slave address (from 1 to 247): MODBUS RTU (JBUS) reserves address 0 not used in MINI Chiller

Function code: contains 3, 6 or 16

Data field: contains data for the function used like register address, number of registers and actual data;

Check word: a cyclic redundancy check (CRC) performed with particular rules for CRC16.

Cyclic Redundancy Check

The CRC is a check word that permits verification of message integrity.

Every message, sent or received, has the CRC check word in the two last characters .

After receiving a request, the slave checks the received message by comparing the received CRC with the calculated one.

When a reply is ready to be sent by the slave, it calculates the CRC word and adds two characters to the prepared message.

CRC calculation is performed on every character of the message, excluding the last two bytes being the CRC.

Error Condition Response

Data	Byte
Slave address	1
Function code + 128	1
Error code	1
CRC-16 (LSB)	1
CRC-16 (MSB)	1

Errors generate a code indicating the cause as follows: 00H = No Error

01H = Illegal Function – code received by the slave device is not recognized

02H = Illegal Data Address – the address does not exist in the slave

03H = Illegal Data Value – the value is not accepted by the slave

04H = Slave Device Failure – an unrecoverable error occurred during slave processing

05H = Acknowledge – the slave accepts the data but needs timeout extension

06H = Slave Busy – the master should try again later

07H = NACK – the slave cannot perform the command, master should request diagnostic

ATC Mini Chiller - ModBUS Communication Protocol

Function Code 3 is used by the master to read a group of sequential registers present in the slave.

Master request	
Data	Bytes
Slave address (1... 247)	1
Function code (3)	1
First register address (Most Significant Byte)	1
First register address (Least Significant Byte)	1
Number of requested registers (MSB)	1
Number of requested registers (LSB)	1
CRC-16 (LSB)	1
CRC-16 (MSB)	1

Slave reply	
Data	Bytes
Slave address (1... 247)	1
Function code (3)	1
Byte number (n)	1
Data	n
CRC-16 (LSB)	1
CRC-16 (MSB)	1

Each register is 16 bits in length so 2 bytes are required for data. The first byte represents the MSB (Most Significant Byte) while the second byte represent the LSB (Least Significant Byte). For 32 bit floating point numbers, 2 registers (4 bytes) are required.

Example: The master requests slave address 1 to return the values of registers 25 and 26 (0x19 and 0x1A).

Master request	
Data	Byte (Hex)
Slave address	01
Function code (3 = read)	03
First register address (MSB)	00
First register address (LSB)	19
Number of requested registers (MSB)	00
Number of requested registers (LSB)	02
CRC-16 (LSB)	15
CRC-16 (MSB)	CC

Slave reply	
Data	Byte (Hex)
Slave address	01
Function code (3 = read)	03
Byte number	04
Value of the first register (MSB)	00
Value of the first register (LSB)	0A
Value of the second register (MSB)	00
Value of the second register (LSB)	14
CRC-16 (LSB)	DA
CRC-16 (MSB)	3E

The slave reply means register 25 = 0AHex (10 decimal) and register 26 = 14H (20 decimal).

ATC Mini Chiller - ModBUS Communication Protocol

Function Code 6 is used by the master to write data to a single register present in the slave.

Master request	
Data	Bytes
Slave address	1
Function code (6)	1
Register address (MSB)	1
Register address (LSB)	1
Value to write (MSB)	1
Value to write (LSB)	1
CRC-16 (MSB)	1
CRC-16 (LSB)	1

Slave reply	
Data	Bytes
Slave address (1-255)	1
Function code (6)	1
Register address (MSB)	1
Register address (LSB)	1
Written value (MSB)	1
Written value (LSB)	1
CRC-16 (MSB)	1
CRC-16 (LSB)	1

Example: The master requests slave address 1 to write in memory location 770 (0x302) the value 10 (0x0A).

Master request	
Data	Byte (Hex)
Slave address	01
Function code (6)	06
Register address (MSB)	03
Register address (LSB)	02
Value to write (MSB)	00
Value to write (LSB)	0A
CRC-16 (MSB)	A8
CRC-16 (LSB)	49

Slave reply	
Data	Byte (Hex)
Slave address	01
Function code (6)	06
Register address (MSB)	03
Register address (LSB)	02
Written value (MSB)	00
Written value (LSB)	0A
CRC-16 (MSB)	A8
CRC-16 (LSB)	49

ATC Mini Chiller - ModBUS Communication Protocol

Function Code 16 is used by the master to write data to multiple sequential registers in the slave.

Master request	
Data	Byte (Hex)
Slave address (1-254)	1
Function code (16)	1
First register address (MSB)	1
First register address (LSB)	1
Number of requested registers (MSB)	1
Number of requested registers (LSB)	1
Byte count	1
Values	n
CRC-16 (LSB)	1
CRC-16 (MSB)	1

Slave reply	
Data	Byte (Hex)
Slave address (1-254)	1
Function code (16)	1
First register address (MSB)	1
First register address (LSB)	1
Number of written registers (MSB)	1
Number of written registers (LSB)	1
CRC-16 (LSB)	1
CRC-16 (MSB)	1

Example: The master unit requires to the slave 1 to write in the registers 10314 (0x284A) and 10315 (0x284B) the values 100 (0x64) and 200 (0xC8)

Master request	
Data	Byte (Hex)
Slave address	01
Function code (16)	10
First register address (MSB)	28
First register address (LSB)	4A
Number of requested registers (MSB)	00
Number of requested registers (LSB)	02
Byte count	4
Value 1 (MSB)	00
Value 1 (LSB)	64
Value 2 (MSB)	00
Value 2 ((LSB)	C8
CRC-16 (LSB)	C9
CRC-16 (MSB)	A8

Slave reply	
Data	Byte (Hex)
Slave address	01
Function code (16)	10
First register address (MSB)	28
First register address (LSB)	4A
Number of written registers (MSB)	00
Number of written registers (LSB)	02
CRC-16 (LSB)	69
CRC-16 (MSB)	BE

ATC Mini Chiller - ModBUS Communication Protocol

3 Register Map

The ATC MINI Chiller slave address, register start address, write permission, baud rate, parity, duplex and enable are set in the ModBUS Parameter submenu accessible from the MINI Chiller user interface touch screen.

Coil	Parameter
0	Pump in manual.
1	Start / Stop.
8	Pump running.
100	Compressor Overload / Locking
101	Compressor Disconnected
102	Compressor Overcurrent
103	Compressor Abnormal DC Voltage
104	Compressor Overheat
105	Tank Empty
106	Threshold Minimum
107	Threshold Maximum
108	PT100 Open circuit
109	Modbus Error
110	Spare
Holding Register	Parameter
10	Maintenance 1 Day
11	Maintenance 1 Month
12	Maintenance 1 Year
13	Maintenance 2 Day
14	Maintenance 2 Month
15	Maintenance 2 Year
16	Maintenance 3 Day
17	Maintenance 3 Month
18	Maintenance 3 Year
19	Maintenance 4 Day
20	Maintenance 4 Month
21	Maintenance 4 Year
22	Maintenance 5 Day
23	Maintenance 5 Month
24	Maintenance 5 Year
25	Maintenance 6 Day
26	Maintenance 6 Month
27	Maintenance 6 Year
28	Maintenance 7 Day
29	Maintenance 7 Month
30	Maintenance 7 Year
31	Maintenance 8 Day
32	Maintenance 8 Month
33	Maintenance 8 Year
34	Maintenance 9 Day
35	Maintenance 9 Month
36	Maintenance 9 Year
131	Setpoint Input for Deg. C (Read / Write) Integer, 250 = 25.1 deg. C
132	Setpoint Input for Deg. F (Read / Write) Integer, 655 = 65.5 deg. F
133	Setpoint Input for Kelvin. (Read / Write) Integer, 2751 = 275.1 K
140	Current Setpoint mode; Celsius = 0 / Fahrenheit =1 / Kelvin = 2 (Read)
144	Current Output mode; Celsius = 0 / Fahrenheit =1 / Kelvin = 2 (Read)

This Register Map is Copyright 2023 Applied Thermal Controls.

ATC Mini Chiller - ModBUS Communication Protocol

Please refer to the MINI Chiller Parameter Menu settings to establish the specific use of Maintenance 1 to 7.

The offset (start) address of the registers can be adjusted in the MINI Chiller Modbus Parameter Menu.

Up to 41 registers can be read in any ModBUS Function 3 request, however if all are requested at the same time repeatedly, this may impact on performance. An interval of 10 seconds is recommended between requests.

Temperature values are sent according to the Temperature Units setting in the MINI Chiller Parameter Menu.
Pressure values are sent according to the Pressure Units setting in the MINI Chiller Parameter Menu.



Applied Thermal Control Ltd
 39 Hayhill Industrial Estate
 Barrow-upon-Soar, Loughborough
 LE12 8LD, United Kingdom
 +44 (0) 1530 839 998
 Service@thermalexchange.co.uk
 Support@app-therm.com

Operating Manual; Recommended Spares

Annex M-1

DOCUMENT DETAILS

Date	23/JUN/2022	Author(s)	MJH	Page	1 / 2	Revision	2
------	-------------	-----------	-----	------	-------	----------	---

RECOMMENDED SPARES FOR M, EM- & R05-SERIES CHILLERS

Recommended spares include all rotating machinery (i.e. motors, fans), all sacrificial elements (i.e. fuses) and parts that users interact with (dials, fittings). Pricing is available from sales@app-therm.com.

COMMON TO MINI AND ECOMINI

PN	Description	QTY
WA697	Water Pump	1
RA282	Fridge Compressor	1
RA282	Compressor Controller	1
EA787	Compressor Cooling Fan	2
RA287	Fridge Condenser Fan	1
EA512	Power Inlet Fuse	2
EA769	Pump Fuse	1
EA764	DIN Rail Fuse Holder	1
WA643	Self-Sealing Water Bulkhead (SA00016)	2
WA644	Self-Sealing Water Connectors (SA00016)	2
WA642	12mm Push Fit Water Bulkhead	2
WA652	12mm Push Fit Plug	2
EA044	IEC Cordset	1
EA770	Power Inlet Connector Module	1
MA310	Rubber Mounting Feet	4
WA641	Fluid Tank Assembly	1

MINI-SPECIFIC

PN	Description	QTY
EA754	Power Supply	1
EA760	USB Port	1
EA755	Touch Screen Controller NON-RS485	1
EA778	Touch Screen Controller WITH-RS485	1
EA513	Controller Fuse	1
EA762	Pump Relay	1
EA759	Optical Level Switch	2
EA757	Pressure Transducer	1
EA586	RTD Temperature Probe PT100	1
RA285	Solenoid Coil	1

ECOMINI-SPECIFIC

PN	Description	QTY
EA815	Power Supply	1
EA019	NTC Temperature Probe assembly	1
EA812	Speed Control Potentiometer	1
EA813	Speed Control Dial	1
EA816	Low Temperature Cutoff Controller	1



Applied Thermal Control Ltd
39 Hayhill Industrial Estate
Barrow-upon-Soar, Loughborough
LE12 8LD, United Kingdom
+44 (0) 1530 839 998
Service@thermalexchange.co.uk
Support@app-therm.com

Operating Manual; Recommended Spares

Annex M-1

DOCUMENT DETAILS

Date	23/JUN/2022	Author(s)	MJH	Page	2 / 2	Revision	2
------	-------------	-----------	-----	------	-------	----------	---

R05-SPECIFIC

PN	Description	QTY
WA690	BULKHEAD FITTING – 1/2" BSPPF	2
WA716	TANK – 2.3L	1
WA717	TANK CAP – 3/4" BSPPM with seal	1

HARP[®] 134a

Revision: 1
Revision date: April 2020

SECTION 1: Identification of the substance/mixture and of the company/undertaking

1.1 Product identifier

Product name	R134a (1,1,1,2-Tetrafluoroethane)
REACH registration number	01-2119459374-33
CAS No.	811-97-2
EC No.	212-377-0

1.2 Relevant identified uses of the substance or mixture and uses advised against

Product use	Refrigerant, propellant, foam expansion agent. Industrial uses: Uses of substances as such or in preparations at industrial sites Professional uses: Public domain (administration, education, entertainment, services, craftsmen)
Restricted use	Consumer uses: Private households (= general public = consumers)
Description	Gas

1.3 Details of the supplier of the safety data sheet

Company	Harp International Limited
Address	Gellihirion Industrial Estate Pontypridd Rhondda Cynon Taff CF37 5SX UK
Web	www.harpintl.com
Telephone	+44 (0) 1443 842 255
Fax	+44 (0) 1443 841 805
Email	harp@harpintl.com
Email of competent person	safety@harpintl.com

1.4 Emergency telephone number

Emergency telephone number	+44 (0) 1270 502 891 24 hours
----------------------------	----------------------------------

SECTION 2: Hazards identification

2.1 Classification of the substance or mixture

Classification – EC 1272/2008	Compressed gas: H280
-------------------------------	----------------------

2.2 Label elements

Hazard pictograms	
Signal word	Warning
Hazard statement	H280 – Contains gas under pressure; may explode if heated
Precautionary statement	P410+P403 – Protect from sunlight. Store in a well-ventilated place.

2.3 Other hazards

Other hazards	Asphyxiant in high concentrations. May cause cold burns/frostbite.
---------------	--

HARP® 134a

Revision: 1
Revision date: April 2020

SECTION 3: Composition/information on ingredients

3.1 Substances

EC 1272/2008

Chemical name	CAS No.	EC No.	REACH registration number	Concentration (%w/w)	Classification
1,1,1,2-Tetrafluoroethane	811-97-2	212-377-0	01-2119459374-33	90-100%	Compressed gas: H280

The purity of the substance in this section is used for classification only and does not represent the actual purity of the substance as supplied.

SECTION 4: First aid measures

4.1 Description of first aid measures

Inhalation	Move the exposed person to fresh air
Eye contact	Rinse immediately with plenty of water
Skin contact	Frostbite: treat as thermal burns
Ingestion	Ingestion is not considered a potential route of exposure

4.2 Most important symptoms and effects, both acute and delayed

Inhalation	Symptoms may include loss of mobility/consciousness. Victim may not be aware of asphyxiation. Respiratory arrest.
Eye contact	Contact with liquefied gas can cause damage due to evaporative cooling
Skin contact	Contact with liquefied gas can cause damage due to evaporative cooling
Ingestion	Ingestion is not considered a potential route of exposure

4.3 Indication of any immediate medical attention and special treatment needed

Inhalation	If you feel unwell, seek medical advice
Eye contact	Seek medical attention if irritation or symptoms persist
Skin contact	Thaw frosted parts with lukewarm water. Do not rub affected area. Get immediate medical advice/attention.
Ingestion	Ingestion is not considered a potential route of exposure

SECTION 5: Firefighting measures

5.1 Extinguishing media

	This product is not flammable in air under ambient conditions of temperature and pressure. Use extinguishing media appropriate to the surrounding fire conditions.
--	--

5.2 Special hazards arising from the substance or mixture

	At high temperature, toxic and/or corrosive fumes may be produced by thermal decomposition (gaseous hydrogen fluoride (HF), carbon oxides).
--	---

5.3 Advice for firefighters

	Wear self-contained breathing apparatus and protective clothing. Heat may cause the containers to explode. Keep fire exposed containers cool by spraying with water. Fire exposed containers may vent contents through pressure relief devices. In case of fire nearby, remove exposed containers.
--	--

HARP® 134a

Revision: 1
Revision date: April 2020

SECTION 6: Accidental release measures

6.1 Personal precautions, protective equipment and emergency procedures

	Ensure adequate ventilation of the working area. Avoid contact with skin and eyes. Evacuate personnel to a safe area. Wear self-contained breathing apparatus and protective clothing. Vapours are heavier than air. Prevent from entering sewers, basements or workpits. Do not enter confined spaces where gas may have accumulated.
--	--

6.2 Environmental precautions

	Prevent further leakage or spillage if safe to do so.
--	---

6.3 Methods and material for containment and clean up

	Allow to evaporate. Provide adequate ventilation.
--	---

6.4 Reference to other sections

	See section 8 Exposure controls / personal protection See section 13 Disposal considerations
--	---

SECTION 7: Handling and storage

7.1 Precautions for safe handling

	Only experienced and properly instructed persons should handle gases under pressure. Protect containers from physical damage. Do not drag, roll, slide or drop. Do not remove or deface labels. Adopt best manual handling considerations when handling, carrying and dispensing. Secure cylinders in an upright position at all times. Close valves when not in use and when empty. Ensure adequate ventilation of the working area. Do not allow backfeed into the container. Avoid contact with skin and eyes. When using, do not eat, drink or smoke. Never use direct flame or electrical heating device to raise the pressure of the container.
--	---

7.2 Conditions for safe storage, including any incompatibilities

	Keep containers tightly closed. Keep in a cool, dry, well-ventilated area. Store in correctly labelled containers. Keep away from sources of ignition – no smoking. Store out of direct sunlight. Storage temperature: <45°C.
Suitable packaging	Stainless steel, steel.

7.3 Specific end use(s)

	See section 1.2 Relevant identified uses of the substance or mixture and uses advised against for further information.
--	--

SECTION 8: Exposure controls/personal protection

8.1 Control parameters – exposure limit values

Component	CAS No.	Value type (form of exposure)	Exposure limit values	Source
1,1,1,2-Tetrafluoroethane	811-97-2	TWA	1000ppm / 4240mg/m ³	EH40

8.2 Exposure controls

Appropriate engineering controls	Ensure adequate ventilation of the working area. Oxygen detectors should be used when asphyxiating gases may be released. Systems under pressure should be regularly checked for leaks.
----------------------------------	---

HARP® 134a

Revision: 1

Revision date: April 2020

Individual protection measures	Wear protective clothing
Eye/face protection	Approved safety goggles
Skin & body protection	Wear suitable gloves. Wear safety shoes when handling containers.
Respiratory protection	Wear suitable respiratory protection equipment when necessary
Occupational exposure controls	Keep away from food, drink and animal feedstuffs.
Hygiene protection	Good industrial hygiene and safety procedures. Do not eat, drink or smoke when using the product.

SECTION 9: Physical and chemical properties

9.1 Information on basic physical and chemical properties

Appearance - Physical state	Gas
Appearance - Form	Liquefied gas
Colour	Colourless
Odour	Slight ethereal
Odour threshold	No data available
pH	Not applicable
Melting point	-108°C
Boiling point / range	-26°C
Flash point	Not applicable
Evaporation rate	Not applicable
Flammability (solid, gas)	This product is not flammable
Upper explosion limit / Lower flammability limit	Not applicable
Vapour pressure	5.74 bar (20°C)
Vapour density	3.6 (air = 1)
Relative density	No data available
Solubility(ies)	
Water solubility	67 mg/l (25°C)
Partition coefficient: n-octanol/water	1.274
Auto-ignition temperature	>743°C
Decomposition temperature	No data available
Viscosity	
Viscosity, kinematic	No data available
Explosive properties	Not applicable
Oxidising properties	Not applicable

9.2 Other information

Molecular weight	102.03 g/mol (C ₂ H ₂ F ₄)
-------------------------	--

SECTION 10: Stability and reactivity

10.1 Reactivity

	Stable under normal conditions
--	--------------------------------

10.2 Chemical stability

	Stable under normal conditions. The gaseous product in the presence of air can form, under certain conditions of temperature and pressure, a flammable mixture.
--	---

HARP[®] 134a

Revision: 1

Revision date: April 2020

10.3 Possibility of hazardous reactions

	No data is available on this product
--	--------------------------------------

10.4 Conditions to avoid

	Keep away from heat and sources of ignition. Avoid contact with flames and red hot metallic surfaces.
--	---

10.5 Incompatible materials

	Alkaline hydroxides, alkaline earth metals, strong oxidizing agents, finely divided metals.
--	---

10.6 Hazardous decomposition products

	Under normal conditions of storage and use, hazardous decomposition products should not be produced. At high temperature, thermal decomposition can give rise to toxic and corrosive products.
--	---

SECTION 11: Toxicological information

11.1 Information on toxicological effects

Acute toxicity	As with other volatile aliphatic halogenated compounds, through vapour accumulation and/or inhalation of large quantities, the product can cause loss of consciousness and cardiac disorders aggravated by stress and lack of oxygen. Risk of mortality.
Skin corrosion/irritation	Ejection of liquefied gas: frostbite possible
Serious eye damage/irritation	Ejection of liquefied gas: frostbite possible
Respiratory or skin sensitisation	No data available
Germ cell mutagenicity	No data available
Carcinogenicity	No data available
Reproductive toxicity	No data available
STOT single exposure	No data available
STOT repeated exposure	No data available
Aspiration hazard	No data available
Repeated or prolonged exposure	No data available

SECTION 12: Ecological information

12.1 Toxicity

	No data available
--	-------------------

12.2 Persistence and degradability

	Not applicable to gases and gas mixtures
--	--

12.3 Bioaccumulative potential

	Expected to biodegrade and not expected to persist for long periods in an aquatic environment
--	---

12.4 Mobility in soil

	Unlikely to cause ground or water pollution due to its high volatility
--	--

12.5 Results of PBT and vPvB assessment

	Not classified as PBT or vPvB
--	-------------------------------

12.6 Other adverse effects

	Contains fluorinated greenhouse gases. When discharged in large quantities may contribute to the greenhouse effect. Global warming potential: 1430
--	--

HARP® 134a

Revision: 1
Revision date: April 2020

SECTION 13: Disposal considerations

13.1 Waste treatment methods

	Dispose of in accordance with all local and national regulations. Avoid discharges to atmosphere. Refer to manufacturer/supplier for information on recovery/recycling. Dispose of container via supplier only. EWC code: 14 06 01* Chlorofluorocarbons, HCFC, HFC
--	---

SECTION 14: Transport information

Hazard pictograms

	
--	---

14.1 UN number

	UN 3159
--	---------

14.2 UN proper shipping name

	1,1,1,2-TETRAFLUOROETHANE
--	---------------------------

14.3 Transport hazard class(es)

ADR/RID	
Class	2
Labels	2.2
Hazard No. (ADR)	20
Tunnel category	(C/E)
Emergency action code	2TE
IMDG	
Class	2.2
EmS No.	F-C, S-V
IATA	
Class	2.2
Packing instruction	200

14.4 Packing group

	-
--	---

14.5 Environmental hazards

Environmental hazards	Not applicable
Marine pollutant	Not classified as a marine pollutant

14.6 Special precautions for user

	Avoid transport on vehicles where the load space is not separated from the driver's compartment. Ensure container valves are closed, not leaking and caps in place. Ensure containers are firmly secured. Ensure adequate air ventilation.
--	--

14.7 Transport in bulk according to Annex II of MARPOL 73/78 and the IBC Code

	Not applicable
--	----------------

HARP[®] 134a

Revision: 1
Revision date: April 2020

SECTION 15: Regulatory information

15.1 Safety, health and environmental regulations/legislation specific for the substance or mixture

Regulations	REGULATION (EC) No 1907/2006 OF THE EUROPEAN PARLIAMENT AND OF THE COUNCIL of 18 December 2006 concerning the Registration, Evaluation, Authorisation and Restriction of Chemicals (REACH), establishing a European Chemicals Agency, amending Directive 1999/45/EC and repealing Council Regulation (EEC) No 793/93 and Commission Regulation (EC) No 1488/94 as well as Council Directive 76/769/EEC and Commission Directives 91/155/EEC, 93/67/EEC, 93/105/EC and 2000/21/EC.
--------------------	---

15.2 Chemical safety assessment

	CSA has been carried out
--	--------------------------

SECTION 16: Other information

Other information

Text of Hazard Statements in Section 3	H280: Contains gas under pressure; may explode if heated.
Reference materials	HSE publication EH40/2005 Workplace exposure limits (latest edition)
Changes from previous versions	-

Further information

	The information supplied in this safety data sheet is designed only as guidance for the safe use, storage and handling of the product. This information is correct to the best of our knowledge and belief at the date of publication however no guarantee is made of its accuracy. This information relates only to the specific material designated and may not be valid for such material used in combination with any other materials or in any other process. Material users should review the information and recommendations in the specific context of their intended manner of handling, use, processing and storage, including an assessment of the appropriateness of the material in the user's end product, if applicable.
--	---

SAFETY DATA SHEET

HEXID A4 HEAT TRANSFER FLUID

Conforming to Directive 1907/2006/EC

SECTION 1: IDENTIFICATION OF THE SUBSTANCE/MIXTURE AND OF THE COMPANY/UNDERTAKING

1.1. Product Name	Hexid A4
1.2. Supplier	Applied Thermal Control Limited 39 Hayhill Industrial Estate, Barrow upon Soar, Leicestershire, LE12 8LD. United Kingdom. www.app-therm.com
1.3. Telephone Number	+44(0)1530 839998
1.4. Email	sales@app-therm.com
1.5. Emergency Telephone Number	+44(0)1530 839998
1.6. Intended/Recommended Use	Heat Transfer Fluid

SECTION 2: HAZARDS IDENTIFICATION

- 2.1. Classification of the substance or mixture**
The product is not classified as dangerous according to Regulation (EC) No. 1272/2008.
This mixture is not classified as dangerous according to Directive 1999/45/EC.

SECTION 3: COMPOSITION/INFORMATION ON INGREDIENTS

- 3.1. Chemical Nature** Water (CAS 7732-18-5), not classified.
Propylene glycol (CAS 57-55-6) (REACH 01-2119456809-23)
(EINECS 200-338-0) not classified.
Fluorescein (trace) and biocide (trace) not classified.
- 3.2. Food Grade**

SECTION 4: FIRST AID MEASURES

- General advise** No special precautions required. Treat symptomatically.
- 4.1. Eye Contact** Rinse thoroughly with plenty of water, also under the eyelids. Remove contact lenses after a few minutes and continue rinsing. If symptoms persist, call a physician.
- 4.2. Skin Contact** Wash off immediately with plenty of water. If skin irritation persists, call a physician.
- 4.3. Inhalation** Remove to fresh air. If symptoms persist, call a physician.
- 4.4. Ingestion** Rinse mouth with water. Never give anything by mouth to an unconscious person. If symptoms persist, call a physician.

SECTION 5: FIREFIGHTING MEASURES

- 5.1. Extinguishing media**
Use extinguishing measures that are appropriate to local circumstances and the surrounding environment. Water spray, foam, dry powder or CO2. Alcohol-resistant foam
- 5.2. Unsuitable extinguishing Media**
High volume water jet. Do not use a solid water stream as it may scatter and spread fire.
- 5.3. Specific hazards during firefighting**
In fire conditions, toxic decomposition products may be formed (see also section 10). In combustion, emits fumes, smoke, carbon dioxide (CO2) and carbon monoxide (CO). Heating will cause a pressure rise - with severe risk of bursting and explosion, Violent steam generation or eruption may occur upon application of direct water to hot liquids.
- 5.4. Advice for firefighters**
In the event of fire, wear self-contained breathing apparatus. Wear personal protective equipment. Promptly isolate the scene by removing all persons from the vicinity of the incident if there is a fire. Keep containers cool by spraying with water if exposed to fire. Collect contaminated fire extinguishing water separately. This must not be discharged into drains. Burning fluids may be extinguished by dilution with water

SAFETY DATA SHEET

HEXID A4 HEAT TRANSFER FLUID

Conforming to Directive 1907/2006/EC

SECTION 6: ACCIDENTAL RELEASE MEASURES

6.1. Personal precautions

Use personal protective equipment. Avoid contact with skin and eyes. Keep unnecessary and unprotected personnel from entering the area.

6.2. Precaution to protect the environment

Do not flush into surface water or sanitary sewer system. Avoid subsoil penetration.

6.3. Clean-up procedures

Contain the spillage, soak up with non-combustible absorbent material, (e.g. sand, earth, diatomaceous earth, vermiculite) and transfer to a container for disposal according to local / national regulations (see section 13). Keep in suitable, closed containers for disposal. Dike the area of spill to prevent spreading and pump liquid to salvage tank. Treat recovered material as described in section 13 Disposal considerations.

SECTION 7: HANDLING AND STORAGE

7.1. Precautions for safe handling

Keep container tightly closed. Handle in accordance with good industrial hygiene and safety practice. Spills of these organic materials on hot fibrous insulations may lead to lowering of the auto-ignition temperatures possibly resulting in spontaneous combustion.

7.2. Conditions for safe storage

Keep only in the original container.

SECTION 8: EXPOSURE CONTROLS/PERSONAL PROTECTION

8.1. Control parameters

Component: Propane-1,2-diol CAS-No. 57-55-6

Other Occupational Exposure Limit Values EH40 WEL, Time Weighted Average (TWA):, Total vapour and particulates.150 ppm, 474 mg/m³

EH40 WEL, Time Weighted Average (TWA):, Particulate.10 mg/m³

ELV (IE), Time Weighted Average (TWA):, Total vapour and particulates.150 ppm, 470 mg/m³

ELV (IE), Time Weighted Average (TWA):, Particulate.10 mg/m³

8.2. Exposure controls/Appropriate engineering controls

Local exhaust. If this product contains ingredients with exposure limits, use process enclosures, local exhaust ventilation or other engineering controls to keep worker exposure below any recommended or statutory limits.

Personal protective equipment

Respiratory protection Suitable respiratory protective device Combination filter: A-P2

Filter Type Combined particulates and organic vapour type

Hand protection Category short time exposure Break through time > 10 min

Protective index Class 1 When prolonged exposure is expected: Break through time > 120 min

Protective index Class 4 Observe the information of the glove manufacturers on permeability.

Protective gloves should be chosen according to Workplace Safety Assessment.

Gloves recommended according to EN 374 (protection against chemicals).

Material Chemical resistant gloves made of butyl rubber or nitrile rubber category III according to EN 374.

SECTION 9: PHYSICAL AND CHEMICAL PROPERTIES

9.1	Appearance at 20°C	Fluorescent green clear liquid
9.2	Odour	Almost odourless
9.3	Flash point	Boils without flashing
9.4	Ignition temperature	Not Available
9.5	Flammability Limit	Not Available
9.6	Oxidizing Properties	Not Available
9.7	Auto flammability	450°C
9.8	Density at 25°C	~1.036g/cm ³
9.9	pH (as is)	7
9.10	Boiling point	102°C
9.7	Auto flammability	450°C
9.8	Solubility in water	Miscible
9.9	Freezing point	-21°C

SAFETY DATA SHEET

HEXID A4 HEAT TRANSFER FLUID

Conforming to Directive 1907/2006/EC

9.10	Specific Heat Capacity	3.78kJ/kg °K
9.11	Viscosity, Kinetic, at 25°C	3.51mPa.s

SECTION 10: STABILITY AND REACTIVITY

10.1. Reactivity

Stable under recommended storage conditions. No dangerous reaction known under conditions of normal use.

10.2. Chemical stability

No decomposition if stored and applied as directed. Stable under recommended storage conditions. Hygroscopic.

10.3. Hazardous reactions

Hazardous polymerisation does not occur.

10.4. Conditions to avoid

Generation of gas from decomposition causes pressure in closed systems. Keep away from direct sunlight. Avoid high temperatures. Avoid temperatures exceeding the decomposition temperature. Avoid UV light.

10.5. Materials to avoid

Strong acids, Strong bases, Strong oxidizing agents.

10.6. Hazardous decomposition products

Aldehydes, Alcohols, Ether, Organic acids.

SECTION 11: TOXICOLOGICAL INFORMATION

11.1. Toxicity Oral

LD50 : > 20000 mg/kg (rat) This product can present a small hazard if large quantities are swallowed.

11.2. Inhalation

LC50 : 6.15 mg/l (rat; 4 h; vapour) At ambient temperature the exposure to vapours is minimal due to a low volatility rate. Inhalation may cause irritation to the nose, throat, upper respiratory tract and lungs. No deaths occurred

11.3. Dermal

LD50 : > 20000 mg/kg (rabbit) Prolonged skin contact is unlikely to result in absorption of harmful amounts. Skin irritation by prolonged exposure is unlikely. Repeated contact may cause flaking and softening of skin.

11.4. Eyes

Slight irritation is possible. Direct contact with eyes may cause temporary irritation. Corneal injury is unlikely.

11.5. Sensitisation

Patch test on human volunteers did not demonstrate sensitisation properties.

11.6. CMR Carcinogenicity

Animal testing did not show any carcinogenic effects. Information given is based on data obtained from similar substances.

11.7. Mutagenicity

No data available.

11.8. Reproductive toxicity

No data available.

11.9. Specific Target Organ Toxicity

Single exposure no data available. Repeated exposure no data available.

11.10. Other toxic properties

Repeated dose toxicity. In rare cases, repeated excessive exposure to propylene glycol may cause central nervous system effects. Aspiration hazard Due to its physical properties, the substance does probably not pose any aspiration hazard.

11.11. Other relevant toxicity information

Handle in accordance with good industrial hygiene and safety practice.

11.12. Experience with human exposure

Health injuries are not known or expected under normal use.

SAFETY DATA SHEET

HEXID A4 HEAT TRANSFER FLUID

Conforming to Directive 1907/2006/EC

SECTION 12: ECOLOGICAL INFORMATION

12.1. Acute toxicity

Fish - LC50 : 40613 mg/l (Oncorhynchus mykiss; 96 h) (static test)

Daphnia and other aquatic invertebrates - LC50 : 18340 mg/l (Ceriodaphnia Dubia (water flea); 48 h) (static test)

Algae - ErC50 : 19000 mg/l (Pseudokirchneriella subcapitata (green algae); 96 h) (Growth inhibition)

Bacteria - NOEC : > 20000 mg/l (Pseudomonas putida; 18 h) Chronic toxicity

Aquatic invertebrates - NOEC : 13020 mg/l (Ceriodaphnia Dubia (water flea); 7 d) (semi-static test)

12.2. Persistence and degradability

Biodegradability 81 % (anaerobic; Exposure Time: 28 d)(OECD 301 F)

Readily biodegradable 96 % (anaerobic; Exposure Time: 64 d)(OECD 306.)

12.3. Bioaccumulative potential

BCF - 0.09 estimated Low bioaccumulative potential

12.4. Mobility

Estimated Koc < 1, indicating very high soil mobility.

12.5. PBT and vPvB assessment

Not a PBT or vPvB substance or mixture

12.6. Other adverse effects

Do not flush into surface water or sanitary sewer system. Avoid subsoil penetration. This substance is not in Annex I of Regulation (EC) 2037/2000 on substances that deplete the ozone layer.

SECTION 13: DISPOSAL CONSIDERATION

13.1. Waste treatment methods

Disposal together with normal waste is not allowed. Special disposal required according to local regulations. Do not let product enter drains. Contact waste disposal services.

13.2. Contaminated packaging

Empty contaminated packaging thoroughly. They can be recycled after thorough and proper cleaning. Packaging that cannot be cleaned are to be disposed of in the same manner as the product.

13.3. European Waste Catalogue Number

No waste code according to the European Waste Catalogue can be assigned for this product, as the intended use dictates the assignment. The waste code is established in consultation with the regional waste disposer.

SECTION 14: TRANSPORT INFORMATION

Not dangerous goods for ADR, RID, IMDG and IATA.

14.1. EEC Regulations

UNNO None **Class** None **Packing Group** None

Road & Rail Transport (ADR & RID) None **IMDG** Not Applicable **ICOA** None

SECTION 15: REGULATORY INFORMATION

15.1 Classification Not classified as hazardous to users.

15.2 CAS No. 57556

15.3 Risk or Safety phrases None

15.4 Labelling None

SECTION 16: OTHER INFORMATION

Key literature references and sources for data taken from supplier information and data from the "Database of registered substances" of the European Chemicals Agency (ECHA) were used to create this safety data sheet. Other information - The information provided in this Safety Data Sheet is correct to our knowledge at the date of its revision. The information given only describes the products with regard to safety arrangements and is not to be considered as a warranty or quality specification and does not constitute a legal relationship.

The information contained in this Safety Data Sheet relates only to the specific material designated and may not be valid for such material used in combination with any other material or in any process, unless specified in the text.